



## ACDS Series 60Hz

Air Cooled Scroll Compressor Direct Expansion Chillers  
Cooling Capacity: 10 to 180 TR (35 to 633 kW)



R410A



# DUNHAM-BUSH

Products that perform...By people who care

# INTRODUCTION

For more than 100 years, Dunham-Bush has focused on innovative product development. Today, we provide a full portfolio of HVAC/R products from Fan Coil Units to large centrifugal chillers as well as many other innovative green solutions. Our commitment to innovation, matched with an aggressive attitude toward growth, makes Dunham-Bush a leader in global markets. Our product development is tailored to meet the specific needs of customers, building-by-building, country-by-country and region-by-region. No other HVAC/R manufacturer takes this approach to meeting your performance expectations.

ACDS, Air Cooled Scroll Compressor Direct Expansion Chillers, have a cooling capacity range from 10 to 180 TR [35 to 633 kW] in 60Hz version using environmentally sound HFC-410A refrigerant. The entire product line features energy efficiency, installation ease, control flexibility, high reliability, compact footprint and advanced controls. The ACDS range is AHRI certified and ETL listed.

Scroll Compressors are designed for Commercial/Industrial Applications and provide the same high quality and efficiency as Reciprocating or Screw Compressors. They have been developed specifically for use in Packaged Chillers and Condensing Unit products.

Upon shipment, the new ACDS R410A unit is installation-ready with a compact size, reduced weight, and complete factory piping and wiring. Refrigerant charge is included and a thorough factory test under load is conducted on each unit to ensure trouble-free start-up and operation.

# TABLE OF CONTENTS

	Page No		Page No
Introduction .....	2	Dimensional Data .....	16
Nomenclature.....	2	Floor Loading Diagram.....	25
Standard Features & Benefits .....	3	Evaporator Water Pressure Drop .....	27
Unit Features .....	3	Condenser Fan .....	28
Unit Options/ Accessories .....	6	Sound Pressure Data .....	29
Application Data.....	8	Electrical Data .....	30
Selection Procedure.....	11	Typical Wiring Diagram .....	31
Physical Specifications .....	12	Guide Specifications.....	36
Performance Data .....	14		

# NOMENCLATURE

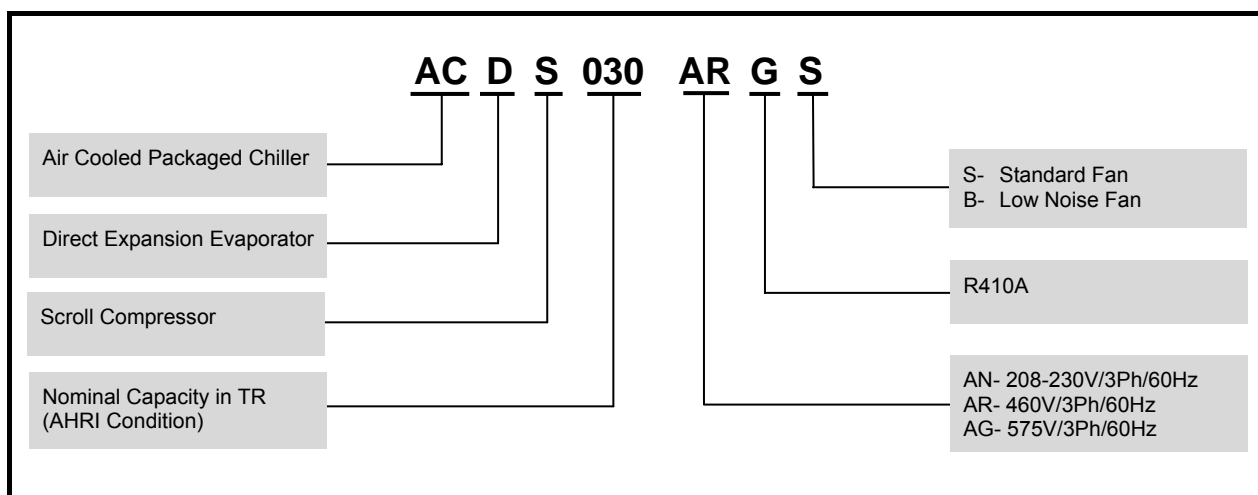

## STANDARD FEATURES & BENEFITS

---

### COMPRESSOR

- ✿ Reliable Tandem or Trio scroll compressors
- ✿ Compressor lead-lag configuration on all models

### EVAPORATOR

- ✿ Compact and high efficiency brazed plate heat exchanger
- ✿ Design pressure of 450 psig [31 bar] on refrigerant circuit
- ✿ Design pressure of 400 psig [28 bar] on fluid circuit

### CONDENSER

- ✿ Copper tubes with aluminum fins
- ✿ Sub-cooling enhancement for efficiency
- ✿ Low noise direct driven propeller fans
- ✿ IP 54 motor construction

### ELECTRICAL/CONTROL

- ✿ Wide range of optional items are available
- ✿ Sizes 10 to 70 TR use electromechanical controller for ease of operation
- ✿ Proactive full function PC Windows® based microcomputer controller, Vision 2020i for sizes 80 to 180 TR
- ✿ Separate power and control panels
- ✿ High/ low pressure limiting function ability

### QUIET OPERATION

- ✿ Quiet scroll compressors on standard unit
- ✿ Ultra-quiet operation with compressor acoustic enclosure available as option

## UNIT FEATURES

---

### SCROLL COMPRESSOR

In a scroll compressor, the compression is performed by two scroll elements located in the upper part of the compressor.

Suction gas enters the compressor at the suction connection. The motor is suction gas cooled, oil droplets separate and fall into the oil sump. After exiting the electrical motor, the gas enters the scroll elements where compression takes place. The refrigerant gas leaves the compressor through the discharge port.

The principle of scroll compression is shown on next page. The centre of the orbiting scroll (in grey) traces a circular path around the centre of the fixed scroll (in black). This movement creates symmetrical compression pockets between the two scroll elements. Low-pressure suction gas is trapped within each crescent-shaped pocket as it gets formed; continuous motion of the orbiting scroll serves to seal the pocket, which decreases in volume as the pocket moves towards the centre of the scroll set increasing the gas pressure. Maximum compression is achieved once a pocket reaches the centre where the discharge port is located; this stage occurs after three complete orbits. Compression is a continuous process: the scroll movement is suction, compression and discharge all at the same time.

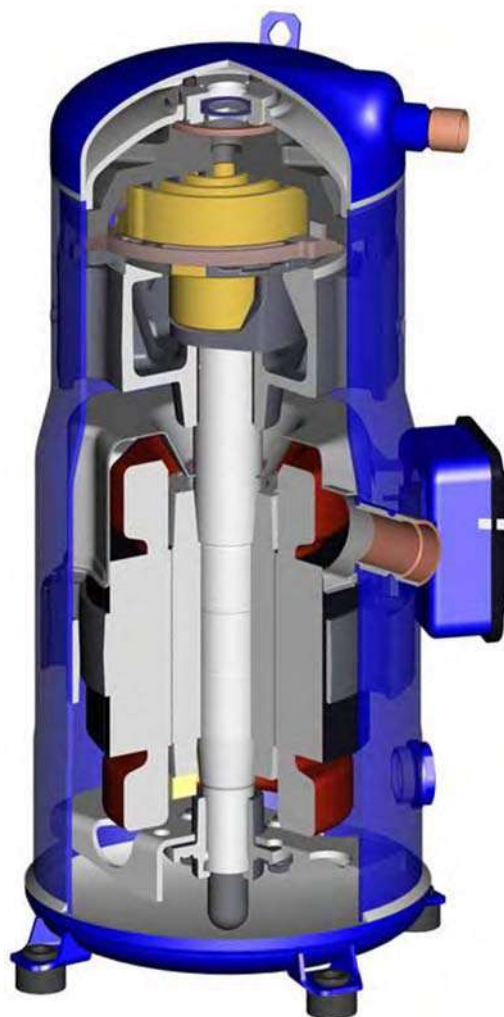

# UNIT FEATURES

## Principle Of Scroll Compression

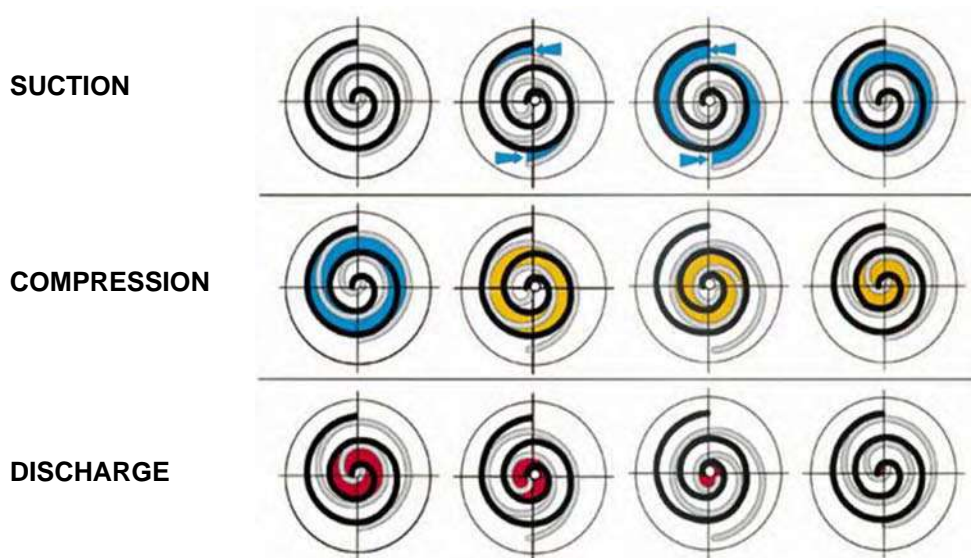

## BRAZED PLATE HEAT EXCHANGER (BPHE)

BPHE represents the cutting edge of heat exchanger technology – one of the most effective and efficient thermal transfer solutions in the world today.

Extremely Compact - reduction in the volume and weight of a shell-and-tube exchanger of the same capacity. This means great design freedom for every application- and reduced installation costs.

Maximum Material Efficiency - no "dead zone" outside gaskets because there is no need for gaskets.

Reduced Refrigerant Charge - the compact system requires only a fraction of the heat transfer medium, e.g. refrigerant. Less volume costs less-and is positive for the environment.

Lower System Costs - better heat transfer coefficient (HTC) gives better  $\Delta T$  (temperature difference), which in turn means a lower mass flow of media, resulting in smaller, less expensive pumps, etc. and lower energy consumption.

Small Temperature Difference - operates efficiently even at temperature differences as low as 1 K.

High Working Pressure - capability.

Low Pressure Drop - in most case lower than in any other system. Allows smaller pumps and lower operating costs.

True Counter Flow - design allows close temperature approach.

Self-Cleaning - thanks to high turbulence throughout the exchanger, reducing maintenance time and cost.



Uniform High Quality - plates are pressed in the same tool, brazed in the same automated procedure with rigorous standards of quality control. Performance is known and consistent. Maintenance and repair are minimized.

# UNIT FEATURES

---

## AIR SIDE CONDENSER

All units have direct drive propeller fans and motors. Close blade tip clearance with the fan venturis assure smooth, quiet operation.

All air-cooled condensers are formed of 3/8 inches [9.5mm] diameter copper tubes mechanically expanded into aluminum fins for maximum efficiency of heat transfer between the circulating refrigerant and air. The fins have full-spacing collars which completely cover each tube. The staggered tube design improves the thermal efficiency of the coil and eliminates bypassing of air around the tubes. The return bends, headers and nipples are all copper, sized for minimum pressure drop, brazed with inert gas in the tubes and tested after fabrication to 650 psig [44.8 bar].

A separate subcooling circuit is standard on all units to maximize energy efficiency.

Fan cycling control is supplied as a standard. This lowers the minimum ambient temperature at which the package equipment will effectively start and operate. For lower ambient requirements than standard, variable speed options are available.

## ELECTRICAL / CONTROL

### STARTER/CONTROL PANELS

The starter/control panels provided on these units are some of the finest available in our industry. Panel enclosures are made of heavy gauge steel. Wires and terminal strips are numbered to simplify installation, maintenance and service. Wires are bundled together with plastic wire ties and all wires are cut to length, without any doubling-back or extraneous wire.

The starter-control panel is furnished completely with all starting equipment, safety controls and automatic controls factory mounted, prewired and set. Control voltage is 115 volts on all units. All power components are prewired to a single terminal block sized for copper conductors. Multiple source power connections on remote wired starters are not required.

### POWER PANEL

Factory wire DOL starters for compressor(s), condenser fan motor(s), with indicating lights.

Anti-recycling timer will be provided to prevent compressor short cycling. DOL starters are mounted in the units. Reduced voltage starter available.

## SAFETY CONTROLS

### 3 Phase Starters With Thermal Overload Protection

These devices react quickly to an overload

condition giving prompt protection to each compressor. They are manually reset.

### High Low Pressure Switch (10-70TR)

A high-low pressure switch is provided with every refrigerant circuit. The high pressure is sensing condensing pressure, with a manual reset. It opens the compressor run circuit. The low pressure senses evaporating pressure. If there is a danger of fluid freeze-up, depending on the cooling fluid used in the building system, the machine will shut down, with a manual reset required.

### Freeze Protection Thermostat (10-70TR)

This thermostat senses outlet chiller fluid (or other liquid being cooled) and will trip if the temperature drops below its pre-set minimum. The control is a manually reset device.

### Compressor Motor Protection

ACDS scroll compressors have a motor protection system consisting of an external electronic control module connected to a chain of embedded PTC (Positive Temperature Coefficient) sensors. The sensors are calibrated for proper motor protection in case of motor overheating caused by overload, low refrigerant flow, incorrect motor rotation, etc. The module has 30 minutes time delay before reset in the event of protector trip.

## AUTOMATIC CONTROLS

### Multi-Step Operating Control

This device controls the operation of the compressor(s) by sensing the return chilled fluid temperature. On standard multiple compressor units this device is a precise solid-state controller providing smooth and repeatable operation.

### Anti-Recycle Timer

Each compressor has an anti-recycle timer built in the controller, which prevents restart for five minutes after a start. The purpose of this device is to avoid excessive motor winding temperature rise and impose undue wear on starters and is fitted as standard.

### Fan Pressure Switch (Automatic)

This switch is used to stage condenser fans "on" or "off" for maintaining adequate discharge pressures for proper system operation by controlling air flow across the control coil.

# UNIT FEATURES

---

## TEMPERATURE CONTROLLER

### Fluid Temperature Control

Control of the fluid temperature is achieved by an intelligent microprocessor thermostat which allows simple user configuration. The controller will arrive on site with the factory settings listed opposite. As all systems are not the same these presets may require changing to suit site conditions. Note that the chilled fluid setpoint should not be set below 4.5°C without the use of Glycol in the fluid system to prevent freezing.

### Timer Between Compressors

The timer does not allow multiple compressors

on a unit to start at the same time. This minimizes electrical demand and wiring cost.

## UNIT CASING

All GI steel panels are powder coated paint which gives excellent finishing, weather and corrosion resistance. Before ED (Electrophoresis Deposition) coating, the part undergoes a complete pre-treatment process which involves degreasing, phosphating and rinsing with deionized fluid. It increases the effect of paint adhesion and rust preventing to obtain high quality paint film. Powder coating is the best painting system which can even coat inaccessible places like the edges, joints or interior surface of hollow sections.

# UNIT OPTIONS / ACCESSORIES

---

Options are installed at the factory. Accessories are shipped loose.

## OPTIONS

### Low Noise Fan (LN)

For applications where reduced sound levels are required. Provide the quietest operating refrigeration equipment possible.

### Compressor Acoustic Jacket (LN2)

Compressor acoustic jackets have been developed to meet specific extra-low noise requirements. They are made from high performing sound proof material and offer excellent high and low frequency attenuation.

### Low Ambient Control (LA1) Minimum ambient 30°F [-1.1°C]

Units use standard fan cycling in conjunction with coil solenoid control to operate down to 30°F [-1.1°C].

### Low Ambient Control (LA2) Minimum Ambient 0°F [-17.8°C]

The incorporation of both variable frequency drive for the condenser motor(s) and coil solenoid control will enable the chiller to operate down to 0°F [-17.8°C].

### Extra Low Ambient Control (LA3) Minimum Ambient -20°F [-28.9°C]

Includes LA2 and EEV (Electronic Expansion Valve(s)) options and requires the use of 50% glycol and at least 50% load available at starting.

Heater tape is available as well. Glycol is recommended for additional protection.

### Desuperheaters (DES)

A desuperheater is simply a refrigerant-to-water heat exchanger installed between the compressor and condenser. It is used to reclaim the readily available superheat energy which would otherwise be rejected through the condenser. The desuperheater is a way of obtaining 'free' heat from the chiller.

### Copper Fin Condenser (COP)

Copper fin and tube condenser.

### Poly Fin Condenser (HYD)

The material is a polyester coating baked onto the aluminum fin stock prior to final manufacture, rather than material applied to the assembly after formation of the coils. The pre-coated fin material has been tested for salt spray corrosion resistance using ASTM B117 specification.

### Convenience Outlet (CON)

Dual 3-pin ground fault receptacle powered from a dedicated transformer and fused for 15 amps.

### Hot Gas Bypass (HGBP)

To maintain units on-line when the minimum load is below the mechanical unloading range. This minimizes compressor cycling and extends component life, on extra low load conditions.

### Weather Proof Alarm Bell (WPA)

Mounted and wired to indicate a common alarm fault.

## UNIT OPTIONS / ACCESSORIES

---

### **Gauges (GAG)**

Includes suction and discharge pressure gauges for all unit models. The microcomputer where fitted also displays discharge and suction pressure.

### **Over and Under Voltage Protection Relay (UVR)**

Combined relay offering protects against high and low supply voltage conditions as well as single phasing, phase reversal and phase imbalance by interrupting the control circuit. It is an automatic reset device, but the microcomputer can be set up for manual reset to prevent unwanted restarts.

### **Unit Ground Fault Interrupt (GFI)**

This takes the unit off line if a ground fault is detected.

### **Optional full length painted steel louvers (LUV)**

For the maximum protection of condenser fins and mechanical components.

### **Low Ambient Lock-Out (LAL)**

Uses an ambient sensor and requires a lock-out set point entered into the microcomputer controller.

### **3-Phase Voltmeter With Selection Switch (VM3)**

Single analog voltmeter installed with a 3 phase selector switch for indication, located inside the control panel.

### **3-Phase Amperage Meter With Selection Switch (AM3)**

Single analog ammeter with a 3 phase selector switch for indication, located inside the control panel.

### **VISION 2020i - optional for sizes 10- 70TR (V2C)**

Vision 2020i is a flexible and advance programmable electronic controller designed specifically for the applications and precise control of Dunham-Bush chillers.

### **System Voltage Measurement (VOLT)**

A voltage transducer is added to display the system voltage on the unit microprocessor. This options is only applicable for units with Vision 2020i controller only.

### **DB Director (DBD)**

DB Director is a full function microcomputer with Windows® based PC interface. All information is displayed using common terms that are easy to understand. The alphanumeric liquid crystal display (LCD) utilizes easy to understand menu-

driven software. DB Director is the optional controller offered for all the models.

### **IP55 Control Panel (IP55)**

A fully enclosed electrical control panel built in accordance with IP55 construction.

### **Remote Fluid Temp Monitoring (RFTR)**

Unit control is based on leaving fluid temperature with a specific temperature differential (range), so the return fluid temperature is for information only.

### **Demand Limiting (AMPL)**

Requires a remote analogue input signal that is used to cycle compressors to limit electrical demand.

### **Evaporator Heater (EVH)**

Heater provide protection from freezing out to -20°F[-28.9°C] ambient.

### **Hydronic Pump Package (HPP)**

This option adds circulating pumps, complete with insulated expansion tank. Available in a single or dual (duty & standby) evaporator versions, with total dynamic head external to the chiller for 50 feet.

## ACCESSORIES

### **Water Flow Switch (WFS1)**

Paddle type field adjustable flow switch. Must be tied into the unit safety circuit so that the package will remain off until fluid flow is proved. Helps prevent evaporator freeze up. NEMA 1 enclosure, for use on fluid, ethylene or propylene glycol circuits. For applications where fluid and ambient temperature are at a minimum 32°F [0°C].

### **Water Flow Switch (WFS4)**

Paddle type field adjustable flow switch. Must be tied into the unit safety circuit so that the package will remain off until fluid flow is proved. Helps prevent evaporator freeze up. NEMA 4 enclosure, for use on fluid, ethylene or propylene glycol circuits. For applications where fluid and ambient temperature are at a minimum 62°F [16.7°C].

### **Rubber-in-shear Isolators (RIS)**

Designed for ease of installation, these rubber, one piece, molded isolators have slip resistant base plates. Applicable for most installations.

### **Spring Isolators (SPG)**

Designed for 1" [25.4mm] deflection, these enclosed spring assemblies have a neoprene friction pad on the bottom to help prevent the transmission of noise and a lock bolt for leveling. Neoprene inserts prevent contact between the steel upper and lower housings. Suitable for more critical applications than RIS isolators.

# APPLICATION DATA

## Evaporator Design Data

1. **Maximum** - Leaving chilled fluid temperature (LCFT) is 60°F [18°C]. The unit can start and pull down with up to 80°F [27°C] entering-fluid temperature. For sustained operation, it is recommended that the entering fluid temperature not exceed 70°F [21°C].
2. **Minimum** - LCFT is 40°F [5.5°C] for all models. Medium temperature glycol application selections from 20°F [-6.6°C] to 39°F [3.9°C] are available from the factory.
3. Minimum/Maximum Flow Rates - refer to Physical Data.
4. Pressure Drop Data - refer to pressure drop and glycol correction factors.
5. Wide Range  $\Delta T$  - Low Flow Applications
  - a. Multiple smaller chillers may be applied in series, each providing a portion of the design temperature range typical 10°F [5.5°C] each.
  - b. Chilled fluid may be recirculated through the evaporator as shown below to allow the chiller to operate with acceptable flow rates and temperature ranges (Figure 1A).

**Figure 1A**

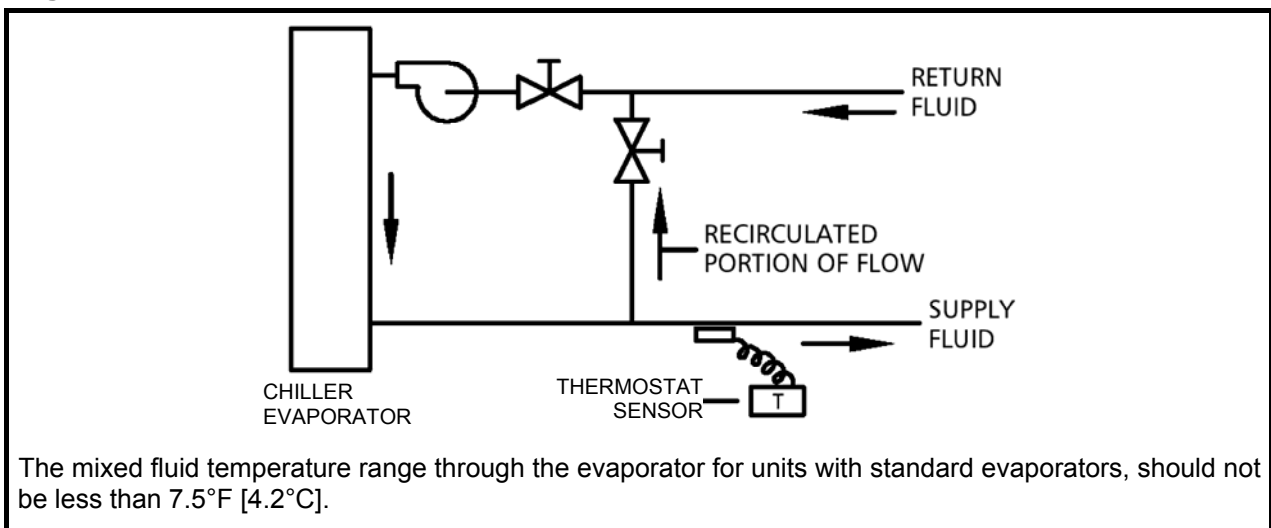

6. Narrow Range  $\Delta T$  - High Flow Applications
  - a. For Extra-Narrow Range  $\Delta T$  applications a partial evaporator bypass piping and valve configuration can be used as shown below.

This permits a higher  $\Delta T$  and lower  $\Delta P$  (pressure drop) through the evaporator (Figure 1B).

**Figure 1B**

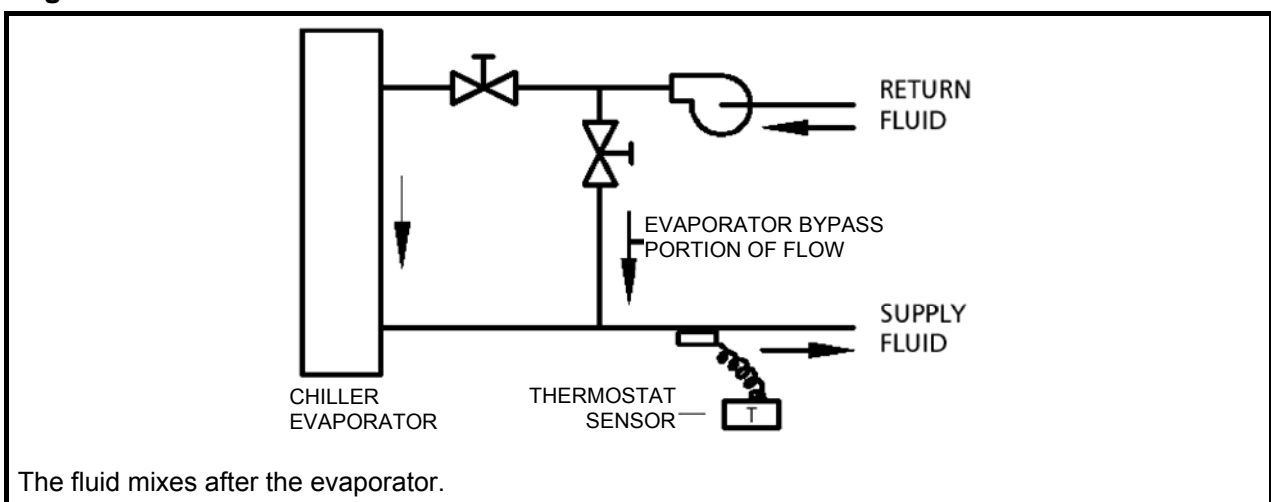

# APPLICATION DATA

## Minimum Chilled Fluid Loop Volume

Model ACDS	Air Conditioning Applications		Process Applications				
	USgal	Liters	USgal	Liters		USgal	Liters
010	30	114	60	211	to	108	380
020	60	229	120	422	to	216	760
030	90	343	180	633	to	324	1140
040	120	457	240	844	to	432	1519
050	150	572	300	1055	to	540	1899
060	180	686	360	1266	to	648	2279
070	210	800	420	1477	to	756	2659
080	240	914	480	1688	to	864	3039
090	270	1029	540	1899	to	972	3419
100	300	1143	600	2110	to	1080	3798
120	360	1372	720	2532	to	1296	4558
135	405	1543	810	2849	to	1458	5128
150	450	1715	900	3165	to	1620	5698
165	495	1886	990	3482	to	1782	6267
180	540	2057	1080	3798	to	1944	6837

\*Values calculated for AHRI Conditions of Service (C.O.S.)

Type of Application	USgal/TR	l/kW	USgal = USgal/TR x AHRI Capacity in TR
Normal Air Conditioning	3	3.25	Liters = l/kW x AHRI capacity in kW
Process Cooling	6 -10	6.5 -10.8	

For applications with other than AHRI C.O.S. calculate the system loop volume based on the adjusted or corrected unit capacity.

### Tanks for System Volume Enhancement

It may be necessary to install a tank in the system to provide sufficient system fluid volume, as shown below. The tank should be baffled and piped for proper fluid mixing to prevent stratification.

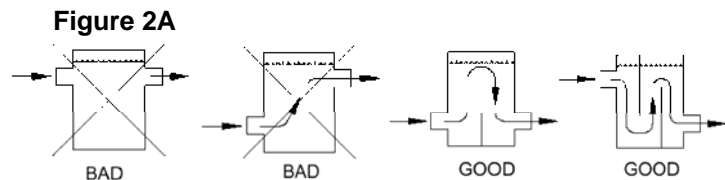

Figure 2B Single Loop System with Storage Tank to Increase Loop Volume

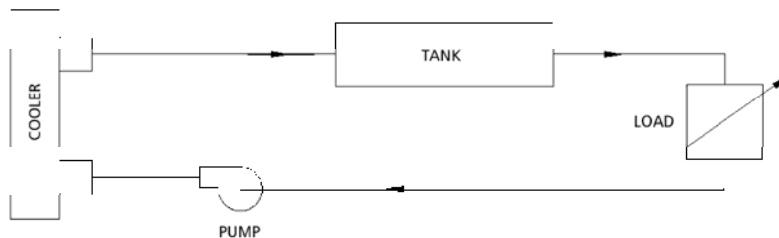
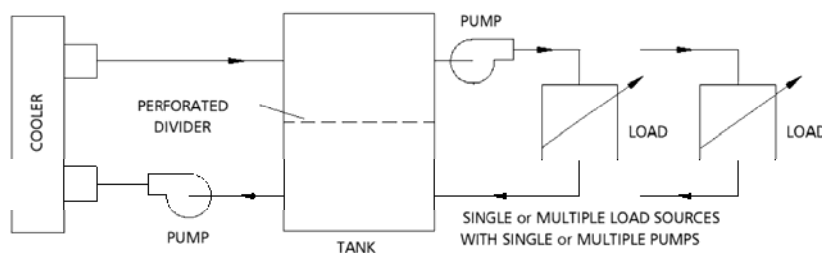

Figure 2C Primary and Secondary Loop Systems are normally used where the secondary system has variable flow and/or multiple loads. See example below.



# APPLICATION DATA

## MULTIPLE CHILLERS PER CHILLED WATER SYSTEM

1. Where the load is greater than available from one ACDS, where standby capacity is required or the load profile dictates, multiple chillers may be piped in parallel. Units of equal size help to ensure fluid flow balance, but balancing valves ensure balanced flows even with dissimilar sized chillers. Temperature controller sensors may or may not need to be moved to the common fluid piping depending on the specific application.
2. Parallel Chiller Applications (Figure 3A). Both units operate simultaneously modulating with load variations. Each unit operates independently sensing its own leaving fluid temperature. The set point of each thermostat is set to maintain the desired loading scheme.

**Figure 3A**

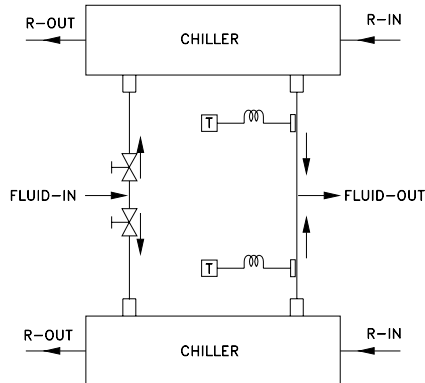

3. Series Chiller Applications (Figure 3B) Where a large temperature range is required (over 25 °F [13.9 °C]), the chiller may be piped in series. In this case the units are controlled independently. The load is progressive by temperature so the chiller selections are critical.

**Figure 3B**

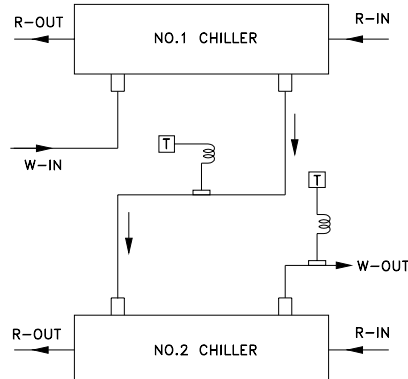

## Oversizing Chillers

Oversizing of chillers more than 5-10% is not recommended. Oversizing causes energy inefficiency and shortened compressor life due to excessive compressor cycling. Future load requirements may result in temporary oversizing of equipment which will require careful unit selection. It may be better to properly size for the initial load and add another unit later for future increase. The use of multiple units is recommended where operation at minimum load for prolonged periods is expected and goal control required. Fully loaded equipment operates better and more efficiently than large equipment running at or near minimum capacity.

Hot gas bypass should not be a means to allow oversizing of chillers. Hot gas bypass should only be used where the equipment is sized properly for full load but the minimum load expected is lower than can be achieved by mechanical unloading is less than the minimum unloading step available.

## Sound and Vibration

The compressors in ACDS units are resiliently mounted to reduce the transmission of any noise and vibration to the frame.

The compressors are not mounted on springs because extra movement may cause line breakage and refrigerant leaks. Unit isolation helps prevent any remaining sound or vibration from entering the building structure, piping or electrical service.

## Water (Fluid) Strainers

It is recommended that 40-mesh strainers be installed in the fluid piping as close to unit evaporator as possible.

# SELECTION PROCEDURE

## Design Requirements

The following design requirements must be known in order to select a packaged chiller.

- \*1.) Required cooling capacity in TR [kW].
  - 2.) Evaporator outlet fluid temperature °F [°C].
  - \*3.) USgpm of chilled fluid to be circulated.
  - \*4.) Chilled fluid cooling range (fluid in °F[°C]- fluid outlet °F[°C])
  - 5.) Design ambient temperature °F[°C].
  - 6.) Electrical power characteristics.
  - 7.) Special codes (local, state or national codes) with which unit must comply
- \*Any 2 out of 3 must be known

### EXAMPLE

Select an air cooled packaged chiller for the following conditions:

100 TR at 54°F [12.22°C] entering, 44°F [6.67°C] leaving chilled fluid. R410A refrigerant design ambient is 95°F [35°C]. Minimum operating ambient is +0°F [-17.78°C]. Altitude is 2000 feet [609.6m]. Chiller fouling factor 0.0005. Electrical characteristics 460V/3/60Hz with single power connection.

### Step 1- Unit Selection

For 2000 feet [609.6m] elevation divide the specified tonnage by the capacity correction factor from Table 4.

$$\frac{100 \text{ TR}}{0.99} = 101 \text{ TR}$$

For 0.0005 fouling factor divide the required tonnage at 2000 feet [609.6m] by the fouling correction factor from Table 5.

$$\frac{101 \text{ TR}}{0.978} = 103.3 \text{ TR}$$

Entering the capacity data for R410A we see that an ACDS 100 unit for water at sea level has a capacity of 100.78 TR, drawing 108.72 compressor kW. The kW correction factors from Table 4 and 5 will be applied to the compressor kW below. For the conditions specified, the unit will do:

$$\begin{aligned} \text{Capacity} &= 100.78 \times 0.99 \times 0.978 = 88.70 \text{ TR} \\ \text{Compressor kW} &= 108.72 \times 1.01 \times 0.99 \\ &= 108.71 \text{ kW} \end{aligned}$$

### Step 2- Evaporator USgpm and Pressure Drop

$$\begin{aligned} \text{USgpm} &= \frac{\text{Specified TR} \times 24}{\text{Cooling Range}} = \frac{100 \times 24}{10} \\ &= 240 \text{ USgpm [54.50m}^3\text{/hr]} \end{aligned}$$

### Step 3- Chilled Fluid Pump Selection

To the pressure drop calculated in Step 2, add the pressure drop through the chilled fluid loop piping, valves and equipment. This will be the foundation of your pump selection criteria.

## Glycol Freeze Protection

If the chiller or fluid piping is to be exposed to temperatures below the freezing point of fluid, glycol protection is recommended. The recommended protection is 10°F [5.6°C] below the minimum ambient temperature. Use only glycol solutions approved for heat exchanger duty. The use of automotive anti-freeze is not recommended because they have short-lived inhibitors and fouling of the vessels will occur. If the equipment is exposed to freezing temperatures and not being used, the vessels and the piping should be drained.

The freeze protection level should be 10°F [5.6°C] lower than the leaving brine temperature. The use of glycol causes a performance derate as shown in Table 2 for ethylene glycol and Table 3 for propylene glycol and needs to be included in the unit selection procedure.

**Table 2 : Ethylene Glycol**

% E. G. By Weight	Freeze Point		C1 Capacity Factor	K1 kW Rate	G1 Flow Factor	P1 P.D. Factor
	°F	°C				
10	26.2	-3.2	0.995	0.998	1.019	1.050
15	22.4	-5.3	0.991	0.997	1.030	1.083
20	17.8	-7.9	0.988	0.996	1.044	1.121
25	12.6	-10.8	0.984	0.995	1.060	1.170
30	6.7	-14.1	0.981	0.994	1.077	1.219
35	0.0	-17.8	0.977	0.992	1.097	1.275
40	-10.0	-23.3	0.973	0.991	1.116	1.331
45	-17.5	-27.5	0.968	0.990	1.138	1.398
50	-28.9	-33.8	0.964	0.989	1.161	1.466

**Table 3 : Propylene Glycol**

% P. G. By Weight	Freeze Point		C2 Capacity Factor	K2 kW Rate	G2 Flow Factor	P2 P.D. Factor
	°F	°C				
10	26.1	-3.3	0.988	0.994	1.005	1.019
15	22.8	-5.1	0.984	0.992	1.008	1.031
20	19.1	-7.2	0.978	0.990	1.010	1.051
25	14.5	-9.7	0.970	0.988	1.015	1.081
30	8.9	-12.8	0.962	0.986	1.021	1.120

**Table 4 : Correction Factor - Elevation**

Elevation above Sea Level		Capacity Correction Factor	kW Correction Factor
Feet [m]	Meters Factor		
0	0	1.00	1.00
2000 [609.6m]	600	0.99	1.01
4000 [1219.2m]	1200	0.98	1.02
6000 [1828.5m]	1800	0.97	1.03

**Table 5 : Correction Factor - FF**

Fouling Factor		Capacity Correction Factor	kW Correction Factor
Hr.ft².°F/BTU	m².°C/kW		
0.0001	0.018	1.000	1.000
0.00025	0.044	0.993	0.997
0.00050	0.088	0.978	0.990
0.00100	0.176	0.951	0.978

# PHYSICAL SPECIFICATIONS

Model ACDS		010	020	030	040	050	060	070	080
Unit Nominal Capacity	TR[kW]	10.0[35.2]	21.2[74.6]	26.7[94.0]	42.8[150.4]	53.2[187.0]	62.1[218.4]	68.3[240.2]	81.4[286.3]
Unit Nominal Power Input	kW	12.3	25.9	32.0	51.7	65.0	76.8	85.6	101.8
<b>COMPRESSOR</b>									
RPM		3500	3500	3500	3500	3500	3500	3500	3500
Min. % Unit Capacity		50%	50%	50%	25%	25%	25%	25%	25%
No. Of Refrigerant Circuit		1	1	1	2	2	2	2	2
<b>EVAPORATOR</b>									
Water Connector	inches[mm]	2.0 [50.8]	2.0 [50.8]	2.0 [50.8]	2.5[63.5]	2.5[63.5]	2.5[63.5]	2.5[63.5]	2.5[63.5]
Nominal Water Flow / Pressure Drop	USgpm/ft.wg[m <sup>3</sup> /hr / kPa]	24.0/ 11.6 [5.4/ 34.7]	50.7/ 12.3 [11.5/ 36.8]	63.9/ 12.9 [14.5/ 38.6]	101.7/ 15.8 [23.1/ 47.2]	127.2/ 15.7 [28.9/ 46.9]	148.6/ 16.2 [33.7.8/ 48.4]	163.3/ 11.5 [37.1/ 34.4]	194.6/ 13.6 [44.2/ 40.7]
Min/Max. Water Flow	USgpm[m <sup>3</sup> /hr]	23.0/ 73.0 [5.2/ 16.9]	42.0/ 131.0 [9.5/ 29.8]	53.0/ 161.0 [12.0/ 36.6]	72.0/ 216.0 [16.4/ 49.1]	90.0/ 272.0 [20.4/ 61.8]	116.0/ 351.0 [26.3/ 79.7]	121.0/ 363.0 [27.5/ 82.4]	136.0/ 410.0 [30.9/ 93.1]
Min/Max. Water Pressure Drop	ft.wg[kPa]	9.5/ 78.7 [28.4/ 235.2]	8.1/ 65.6 [24.2/ 196.1]	8.3/ 72.0 [24.8/ 215.2]	8.8/ 62.6 [26.3/ 187.1]	8.7/ 63.0 [26.0/ 188.3]	8.6/ 63.0 [25.7/ 188.3]	8.7/ 62.6 [26.0/ 187.1]	8.5/ 61.9 [25.4/ 185.0]
<b>CONDENSER</b>									
Coil Rows Deep/ Total Face Area	ft <sup>2</sup> [m <sup>2</sup> ]	3/ 20.0[1.9]	3/ 40.6[3.8]	4/ 47.1[4.4]	3/ 94.1[8.7]	3/ 94.1[8.7]	4/ 94.1[8.7]	4/ 94.1[8.7]	4/ 133.0[12.4]
Total Air Flow	cfm[m <sup>3</sup> /hr]	10150 [17247]	24740 [42038]	24570 [41749]	51940 [88256]	50380 [85605]	49940 [84858]	48280 [82037]	71400 [121323]
No Of Fan		1	2	2	4	4	4	4	6
Fan Diameter	inches[mm]	30.0[762]	31.5[800]	31.5[800]	31.5[800]	31.5[800]	31.5[800]	31.5[800]	31.5[800.0]
Motor kW <sup>1</sup> (Qty)		1.41 (1)	1.85 (2)	1.85 (2)	1.85 (4)	1.85 (4)	1.85 (4)	1.85 (4)	1.85 (6)
Fan FLA , Amp (Qty)		2.7 (1)	3.4 (2)	3.4 (4)	3.4 (4)	3.4 (4)	3.4 (4)	3.4 (4)	3.4 (6)
Min. Operating Ambient	°F[°C]	45 [7.2]	45 [7.2]	45 [7.2]	45 [7.2]	45 [7.2]	45 [7.2]	45 [7.2]	45 [7.2]
<b>ELECTRICAL</b>									
Nominal Voltage		460/3/60	460/3/60	460/3/60	460/3/60	460/3/60	460/3/60	460/3/60	460/3/60
RLA/ Compressor (Qty), AMPS		12 (2)	21 (2)	27 (2)	21 (4)	27 (4)	27 (2) 36 (2)	36 (4)	36 (2) 46 (2)
Unit Max. Inrush, AMPS		102	175	221	224	275	319	337	398
<b>GENERAL</b>									
Unit Length	inches[mm]	50 1/4 [1276]	90 [2288]	90 [2288]	112 1/4 [2849]	112 1/4 [2849]	112 1/4 [2849]	112 1/4 [2849]	147 1/2 [3747]
Unit Width	inches[mm]	43[1092]	48 1/2[1232]	52[1321]	88[2235]	88[2235]	88[2235]	88[2235]	88[2235]
Unit Height	inches[mm]	53 1/4[1353]	69 3/4[1772]	84 3/4[2154]	82 1/2[2095]	82 1/2[2095]	82 1/2[2095]	82 1/2[2095]	88[2235]
Shipping Weight	lbs[kg]	929[421]	1656[751]	2407[1092]	3030[1375]	3501[1588]	3661[1661]	3767[1709]	4865[2207]
Operating Weight	lbs[kg]	934[424]	1669[757]	2422[1099]	3056[1386]	3535[1603]	3700[1678]	3813[1730]	4918[2231]
Operating Charge R410A	lbs[kg]	26[12]	51[23]	77[35]	101[46]	128[58]	152[69]	179[81]	203[92]

Note: Nominal data is based on evaporator LWT 44°F and condenser ambient 95°F, actual capacity depends on the specified operating conditions.



# PHYSICAL SPECIFICATIONS

Model ACDS		090	100	120	135	150	165	180
Unit Nominal Capacity	TR[kW]	89.8[315.8]	100.8[354.5]	108.4[381.2]	125.4[441.0]	138.5[487.1]	153.0[538.1]	163.7[575.7]
Unit Nominal Power Input	kW	114.8	123.5	133.5	149.3	168.5	182.6	198.7
<b>COMPRESSOR</b>								
RPM		3500	3500	3500	3500	3500	3500	3500
Min. % Unit Capacity		25%	25%	25%	16.7%	16.7%	16.7%	16.7%
No. Of Refrigerant Circuit		2	2	2	2	2	2	2
<b>EVAPORATOR</b>								
Water Connector	inches[mm]	2.5[63.5]	2.5[63.5]	2.5[63.5]	4.0[101.6]	4.0[101.6]	4.0[101.6]	4.0[101.6]
Nominal Water Flow / Pressure Drop	USgpm/ft.wg[m <sup>3</sup> /hr / kPa]	218.5.0/ 13.5 [49.6/ 40.4]	241.1/ 16.2 [54.7/ 48.4]	259.4/ 16.5 [58.9/ 49.3]	300.0/ 11.1 [68.1/ 33.2]	331.2/ 13.4 [75.2/ 40.1]	366.0/ 14.4 [83.1/ 43.0]	391.7/ 13.1 [88.9/ 39.2]
Min/Max. Water Flow	USgpm[m <sup>3</sup> /hr]	161.0/ 484.0 [36.6/ 109.9]	161.0/ 484.0 [36.6/ 109.9]	185.0/ 551.0 [42.0/ 125.1]	210.0/ 400.0 [47.7/ 90.8]	210.0/ 400.0 [47.7/ 90.8]	250.0/ 450.0 [56.8/ 102.2]	270.0/ 480.0 [61.3/ 109.0]
Min/Max. Water Pressure Drop	ft.wg[kPa]	8.3/ 60.0 [24.8/ 179.3]	8.3/ 60.0 [24.8/ 179.3]	8.0/ 57.5 [23.9/ 171.9]	5.1/ 30.0 [15.2/ 89.7]	5.1/ 30.0 [15.2/ 89.7]	5.1/ 30.0 [15.2/ 89.7]	5.1/ 30.0 [15.2/ 89.7]
<b>CONDENSER</b>								
Coil Rows Deep/ Total Face Area	ft <sup>2</sup> [m <sup>2</sup> ]	4/ 133.0[12.4]	4/ 177.3[16.5]	4/ 177.3[16.5]	4/ 235.6[21.9]	4/ 235.6[21.9]	4/ 282.6[26.3]	4/ 282.6[26.3]
Total Air Flow	cfm[m <sup>3</sup> /hr]	71400 [121323]	96960 [164754]	95200 [161764]	124140 [210939]	122850 [208747]	147420 [250496]	147420 [250496]
No Of Fan		8	8	8	10	10	12	12
Fan Diameter	inches[mm]	31.5[800.0]	31.5[800.0]	31.5[800.0]	31.5[800.0]	31.5[800.0]	31.5[800.0]	31.5[800.0]
Motor kW' (Qty)		1.85 (8)	1.85 (8)	1.85 (8)	1.85 (10)	1.85 (10)	1.85 (12)	1.85 (12)
Fan FLA , Amp (Qty)		3.4 (8)	3.4 (8)	3.4 (8)	3.4 (10)	3.4 (10)	3.4 (12)	3.4 (12)
Min. Operating Ambient	°F[°C]	45 [7.2]	45 [7.2]	45 [7.2]	45 [7.2]	45 [7.2]	45 [7.2]	45 [7.2]
<b>ELECTRICAL</b>								
Nominal Voltage		460/3/60	460/3/60	460/3/60	460/3/60	460/3/60	460/3/60	460/3/60
RLA/ Compressor (Qty), AMPS		46 (4)	46 (2) 56 (2)	56 (4)	36 (3) 46 (3)	46 (6)	46 (3) 56 (3)	56 (6)
Unit Max. Inrush, AMPS		425	495	515	494	524	611	641
<b>GENERAL</b>								
Unit Length	inches[mm]	147 1/2[3747]	189[4801]	189[4801]	225 1/2[5728]	225 1/2[5728]	267 1/2[6795]	267 1/2[6795]
Unit Width	inches[mm]	88[2235]	88[2235]	88[2235]	88[2235]	88[2235]	88[2235]	88[2235]
Unit Height	inches[mm]	88[2235]	88[2235]	88[2235]	93[2362]	93[2362]	93[2362]	93[2362]
Shipping Weight	lbs[kg]	5231[2373]	6196[2811]	6309[2862]	7336[3328]	7888[3578]	9120[4137]	9844[4465]
Operating Weight	lbs[kg]	5290[2400]	6264[2841]	6383[2895]	7454[3381]	8005[3631]	9251[4196]	10007[4539]
Operating Charge R410A	lbs[kg]	229[104]	254[115]	304[138]	342[155]	381[173]	419[190]	456[207]

Note: Nominal data is based on evaporator LWT 44°F and condenser ambient 95°F, actual capacity depends on the specified operating conditions.



# PERFORMANCE DATA

LWT °F	MODEL ACDS	AMBIENT TEMPERATURE, °F											
		85			95			105			115		
		TR	kW <sup>i</sup>	EER	TR	kW <sup>i</sup>	EER	TR	kW <sup>i</sup>	EER	TR	kW <sup>i</sup>	EER
40	010	10.08	9.47	11.12	9.23	10.88	9.01	8.39	12.29	7.35	7.54	13.70	5.99
	020	20.90	19.64	10.75	19.28	22.40	8.86	17.66	25.17	7.34	16.04	27.93	6.09
	030	26.84	24.28	11.51	24.75	28.03	9.36	22.67	31.77	7.67	20.59	35.52	6.30
	040	41.39	39.85	10.51	38.11	45.51	8.64	34.84	51.18	7.14	31.56	56.84	5.90
	050	53.20	49.14	11.29	49.01	56.80	9.16	44.83	64.46	7.49	40.64	72.13	6.13
	060	62.15	59.39	11.17	57.14	68.82	9.00	52.14	78.24	7.31	47.13	87.67	5.95
	070	71.40	69.31	11.17	65.58	80.36	8.97	59.77	91.41	7.26	53.95	102.47	5.89
	080	81.65	78.63	10.92	75.03	90.57	8.86	68.41	102.52	7.23	61.79	114.46	5.91
	090	90.35	90.40	10.68	82.80	103.64	8.66	75.25	116.89	7.06	67.71	130.14	5.75
	100	100.98	94.85	11.05	92.92	108.56	9.04	84.85	122.27	7.43	76.79	135.98	6.11
	120	108.84	103.37	11.05	100.04	118.31	9.02	91.23	133.24	7.40	82.43	148.18	6.07
	135	125.40	113.59	11.39	115.69	130.71	9.30	105.99	147.84	7.65	96.28	164.96	6.30
	150	138.72	130.86	11.15	127.65	149.88	9.10	116.58	168.90	7.47	105.51	187.92	6.13
	165	153.05	140.00	11.32	141.07	160.17	9.28	129.09	180.34	7.65	117.11	200.51	6.31
180	164.07	153.94	11.18	150.92	176.11	9.13	137.78	198.27	7.50	124.64	220.44	6.16	
42	010	10.48	9.46	11.57	9.62	10.87	9.40	8.77	12.28	7.69	7.92	13.69	6.29
	020	22.00	19.46	11.40	20.24	22.30	9.34	18.49	25.14	7.69	16.73	27.98	6.34
	030	27.85	24.46	11.87	25.74	28.14	9.70	23.63	31.82	7.98	21.52	35.50	6.59
	040	44.02	38.89	11.41	40.32	44.91	9.25	36.62	50.92	7.53	32.92	56.94	6.14
	050	55.39	49.77	11.63	51.09	57.20	9.49	46.79	64.64	7.79	42.49	72.07	6.42
	060	64.83	59.84	11.57	59.62	69.12	9.35	54.42	78.40	7.61	49.21	87.68	6.21
	070	72.24	67.65	11.55	66.92	79.28	9.26	61.60	90.91	7.52	56.27	102.55	6.14
	080	85.05	78.66	11.37	78.19	90.61	9.23	71.33	102.56	7.53	64.47	114.51	6.16
	090	95.26	90.23	11.28	87.07	103.55	9.11	78.87	116.86	7.40	70.68	130.18	6.00
	100	105.20	94.94	11.50	96.85	108.64	9.42	88.50	122.35	7.74	80.14	136.05	6.38
	120	113.36	103.56	11.49	104.24	118.48	9.39	95.11	133.41	7.70	85.99	148.33	6.33
	135	130.60	113.65	11.86	120.55	130.77	9.69	110.49	147.90	7.97	100.44	165.02	6.57
	150	144.52	130.93	11.61	133.05	149.94	9.48	121.58	168.95	7.78	110.11	187.95	6.40
	165	159.44	140.14	11.79	147.03	160.29	9.67	134.62	180.44	7.97	122.21	200.60	6.58
180	170.94	154.13	11.63	157.32	176.28	9.51	143.70	198.44	7.82	130.09	220.59	6.43	
44	010	10.87	9.45	12.01	10.01	10.86	9.79	9.15	12.27	8.03	8.29	13.68	6.59
	020	23.10	19.28	12.06	21.20	22.20	9.82	19.31	25.11	8.04	17.42	28.03	6.59
	030	28.86	24.64	12.22	26.72	28.25	10.04	24.58	31.86	8.29	22.45	35.48	6.88
	040	46.65	37.94	12.35	42.52	44.31	9.87	38.40	50.67	7.94	34.27	57.04	6.38
	050	57.58	50.40	11.95	53.17	57.60	9.82	48.75	64.81	8.10	44.33	72.01	6.70
	060	67.50	60.29	11.97	62.10	69.42	9.70	56.70	78.56	7.92	51.29	87.69	6.47
	070	73.08	65.99	11.95	68.26	78.20	9.57	63.43	90.41	7.78	58.60	102.63	6.39
	080	88.45	78.69	11.82	81.35	90.65	9.59	74.25	102.61	7.84	67.15	114.56	6.41
	090	100.18	90.06	11.88	91.34	103.45	9.57	82.49	116.83	7.74	73.65	130.22	6.25
	100	109.43	95.02	11.96	100.78	108.72	9.79	92.14	122.42	8.06	83.50	136.12	6.64
	120	117.88	103.74	11.93	108.44	118.66	9.75	98.99	133.57	8.01	89.55	148.49	6.58
	135	135.80	113.70	12.33	125.40	130.83	10.08	115.00	147.96	8.29	104.60	165.08	6.84
	150	150.32	131.01	12.07	138.45	150.00	9.86	126.58	168.99	8.10	114.71	187.98	6.67
	165	165.83	140.27	12.25	152.99	160.41	10.05	140.15	180.55	8.29	127.31	200.68	6.85
180	177.81	154.32	12.09	163.72	176.46	9.89	149.63	198.60	8.13	135.54	220.74	6.69	

**LEGEND**

LWT : Leaving Chilled Water Temperature

kW<sup>i</sup> : Compressor Power Input In kW

TR : Cooling Capacity In TR.

EER : Chiller Energy Efficiency Ratio (Includes power from compressors and fan motors.)

**NOTES:**

1. Rating is based on AHRI Standard 550/590-2003, 10°F water range in evaporator & 0.0001 hr.ft. - °F/BTU fouling factor.

2. Interpolation between ratings is permissible but extrapolation is not.

3. kW<sup>i</sup> is for compressor only. EER is for entire unit.



# PERFORMANCE DATA

LWT °F	MODEL ACDS	AMBIENT TEMPERATURE, °F											
		85			95			105			115		
		TR	kW <sup>i</sup>	EER	TR	kW <sup>i</sup>	EER	TR	kW <sup>i</sup>	EER	TR	kW <sup>i</sup>	EER
46	010	11.26	9.44	12.45	10.40	10.85	10.18	9.54	12.26	8.37	8.67	13.67	6.90
	020	24.19	19.10	12.73	22.16	22.09	10.31	20.14	25.09	8.39	18.11	28.08	6.84
	030	29.88	24.82	12.57	27.71	28.37	10.37	25.54	31.91	8.61	23.37	35.46	7.16
	040	49.29	36.99	13.32	44.73	43.70	10.50	40.18	50.42	8.34	35.62	57.13	6.62
	050	59.78	51.03	12.28	55.24	58.01	10.13	50.71	64.98	8.41	46.17	71.95	6.98
	060	70.18	60.74	12.36	64.58	69.73	10.05	58.98	78.71	8.22	53.37	87.70	6.73
	070	73.93	64.33	12.37	69.59	77.12	9.88	65.26	89.91	8.05	60.92	102.70	6.64
	080	91.86	78.73	12.27	84.52	90.69	9.96	77.18	102.65	8.14	69.84	114.61	6.67
	090	105.09	89.89	12.49	95.60	103.35	10.02	86.11	116.81	8.08	76.63	130.26	6.51
	100	113.65	95.10	12.41	104.72	108.80	10.17	95.79	122.50	8.37	86.85	136.19	6.90
	120	122.40	103.93	12.37	112.64	118.83	10.12	102.87	133.74	8.31	93.11	148.65	6.84
	135	141.01	113.76	12.79	130.26	130.89	10.46	119.50	148.01	8.61	108.75	165.14	7.11
	150	156.11	131.08	12.52	143.85	150.06	10.24	131.58	169.04	8.42	119.31	188.01	6.93
	165	172.22	140.40	12.71	158.95	160.52	10.44	145.68	180.65	8.62	132.41	200.77	7.13
180	184.68	154.51	12.54	170.11	176.64	10.27	155.55	198.76	8.45	140.99	220.88	6.96	
48	010	11.65	9.43	12.90	10.79	10.84	10.57	9.92	12.25	8.71	9.05	13.66	7.21
	020	25.29	18.92	13.42	23.12	21.99	10.80	20.96	25.06	8.75	18.80	28.13	7.09
	030	30.89	25.00	12.92	28.69	28.48	10.70	26.50	31.96	8.92	24.30	35.44	7.45
	040	51.92	36.03	14.35	46.94	43.10	11.15	41.96	50.17	8.75	36.98	57.23	6.87
	050	61.97	51.67	12.59	57.32	58.41	10.45	52.67	65.15	8.71	48.02	71.89	7.27
	060	72.86	61.19	12.75	67.06	70.03	10.39	61.26	78.87	8.52	55.45	87.71	7.00
	070	74.77	62.67	12.80	70.93	76.04	10.20	67.09	89.41	8.32	63.24	102.78	6.89
	080	95.26	78.76	12.72	87.68	90.73	10.33	80.10	102.69	8.45	72.52	114.66	6.92
	090	110.01	89.72	13.09	99.87	103.25	10.48	89.74	116.78	8.42	79.60	130.30	6.76
	100	117.87	95.19	12.86	108.65	108.88	10.54	99.43	122.57	8.69	90.21	136.26	7.17
	120	126.92	104.12	12.81	116.84	119.01	10.48	106.75	133.91	8.61	96.67	148.80	7.09
	135	146.21	113.82	13.26	135.11	130.95	10.85	124.01	148.07	8.93	112.91	165.20	7.38
	150	161.91	131.15	12.98	149.24	150.12	10.62	136.58	169.08	8.74	123.92	188.04	7.20
	165	178.61	140.53	13.17	164.91	160.64	10.82	151.21	180.75	8.94	137.52	200.86	7.40
180	191.55	154.70	12.99	176.51	176.81	10.64	161.48	198.92	8.76	146.44	221.03	7.22	
50	010	12.05	9.42	13.35	11.17	10.83	10.95	10.30	12.24	9.05	9.43	13.65	7.51
	020	26.38	18.74	14.11	24.09	21.89	11.30	21.79	25.03	9.10	19.49	28.18	7.34
	030	31.90	25.18	13.25	29.68	28.59	11.03	27.45	32.00	9.23	25.22	35.42	7.74
	040	54.55	35.08	15.41	49.15	42.50	11.82	43.74	49.91	9.16	38.33	57.33	7.11
	050	64.16	52.30	12.90	59.39	58.81	10.76	54.63	65.32	9.01	49.86	71.83	7.55
	060	75.53	61.64	13.13	69.53	70.33	10.73	63.54	79.03	8.82	57.54	87.72	7.26
	070	75.61	61.01	13.26	72.26	74.96	10.53	68.92	88.91	8.59	65.57	102.86	7.14
	080	98.66	78.80	13.17	90.84	90.77	10.70	83.02	102.74	8.75	75.20	114.71	7.17
	090	114.93	89.56	13.70	104.14	103.15	10.94	93.36	116.75	8.76	82.57	130.34	7.01
	100	122.09	95.27	13.31	112.58	108.96	10.92	103.07	122.64	9.00	93.57	136.33	7.43
	120	131.44	104.30	13.24	121.04	119.19	10.84	110.63	134.07	8.92	100.23	148.96	7.34
	135	151.42	113.88	13.73	139.97	131.01	11.23	128.52	148.13	9.26	117.06	165.26	7.64
	150	167.70	131.23	13.44	154.64	150.18	11.00	141.58	169.12	9.06	128.52	188.07	7.47
	165	185.00	140.66	13.63	170.87	160.76	11.21	156.74	180.85	9.26	142.62	200.95	7.67
180	198.42	154.89	13.45	182.91	176.99	11.02	167.40	199.08	9.08	151.89	221.18	7.49	

**LEGEND**

LWT : Leaving Chilled Water Temperature

kW<sup>i</sup> : Compressor Power Input In kW

TR : Cooling Capacity In TR.

EER : Chiller Energy Efficiency Ratio (Includes power from compressors and fan motors.)

**NOTES:**

1. Rating is based on AHRI Standard 550/590-2003, 10°F water range in evaporator & 0.0001 hr.ft. - °F/BTU fouling factor.
2. Interpolation between ratings is permissible but extrapolation is not.
3. kW<sup>i</sup> is for compressor only. EER is for entire unit.

# DIMENSIONAL DATA

## ACDS 010

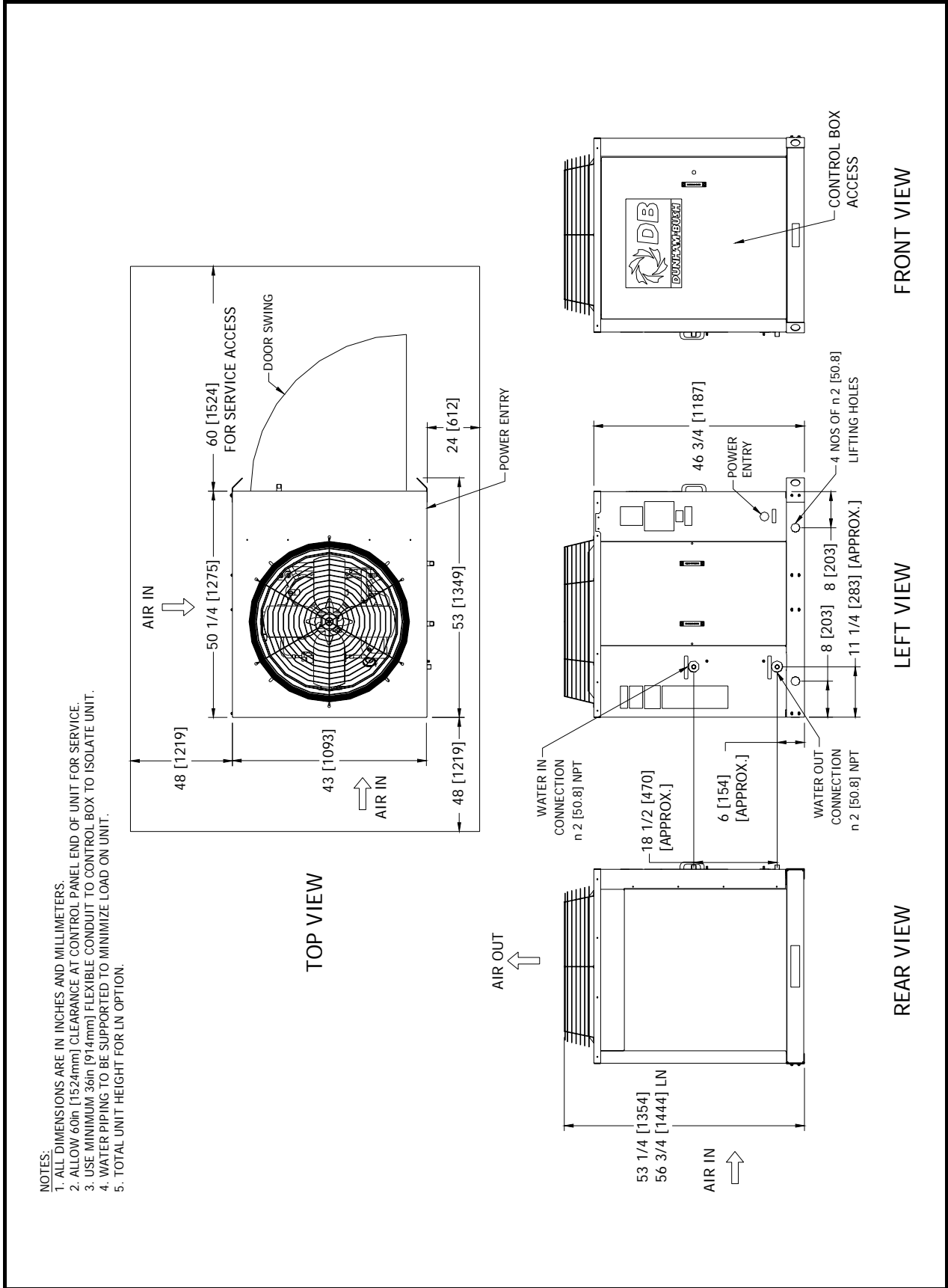

# DIMENSIONAL DATA

## ACDS 020

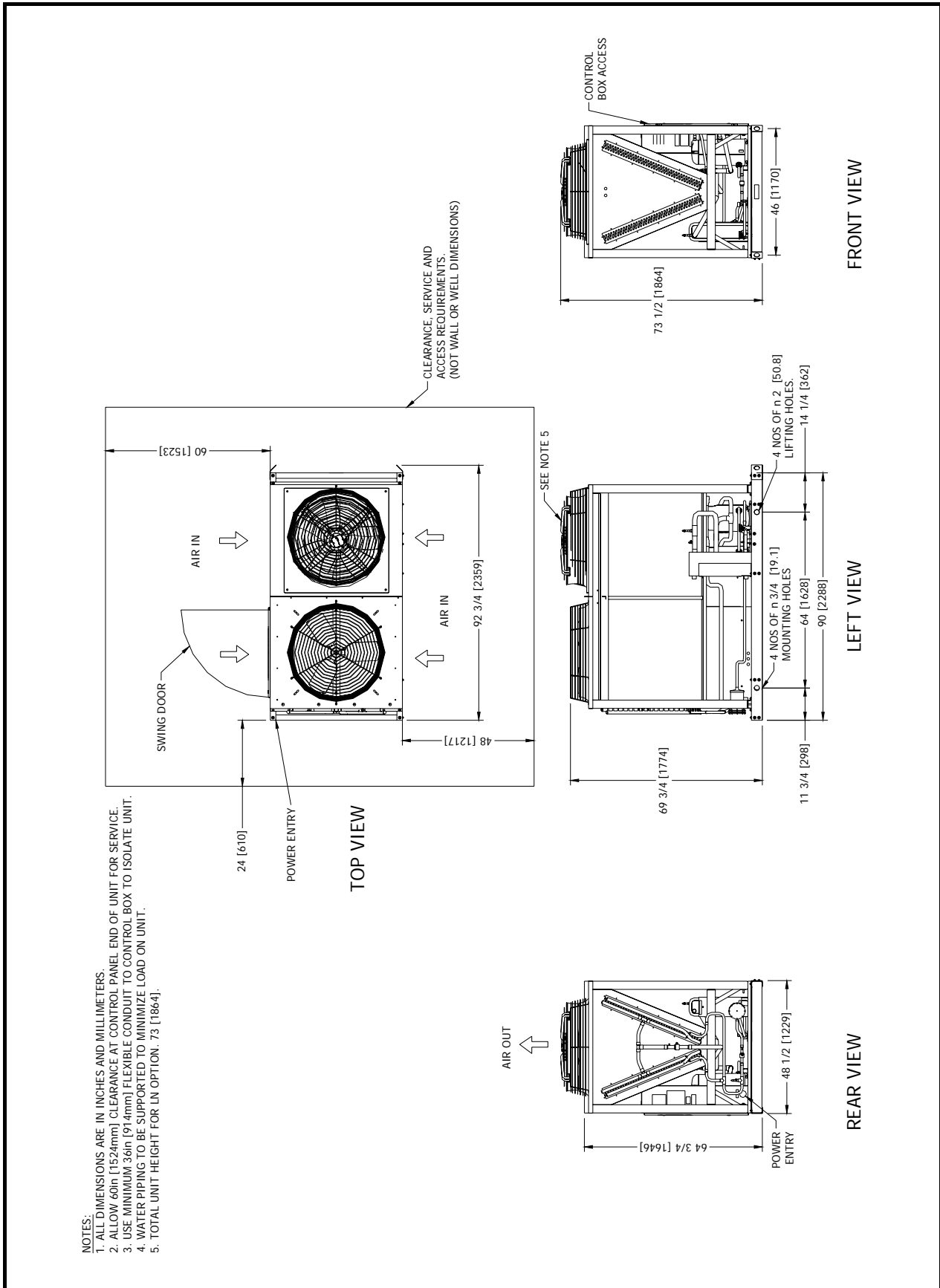

# DIMENSIONAL DATA

## ACDS 030

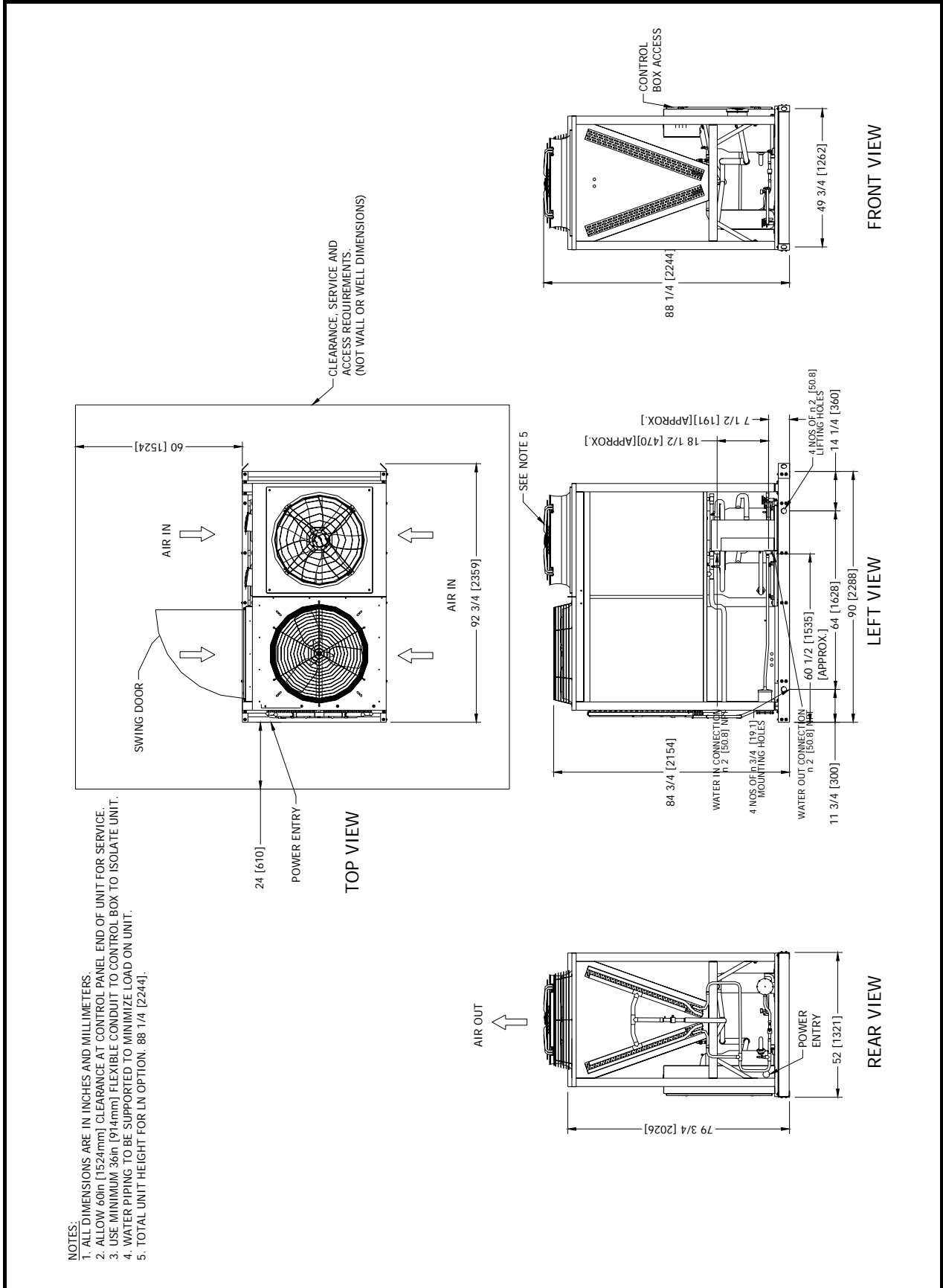

# DIMENSIONAL DATA

## ACDS 040

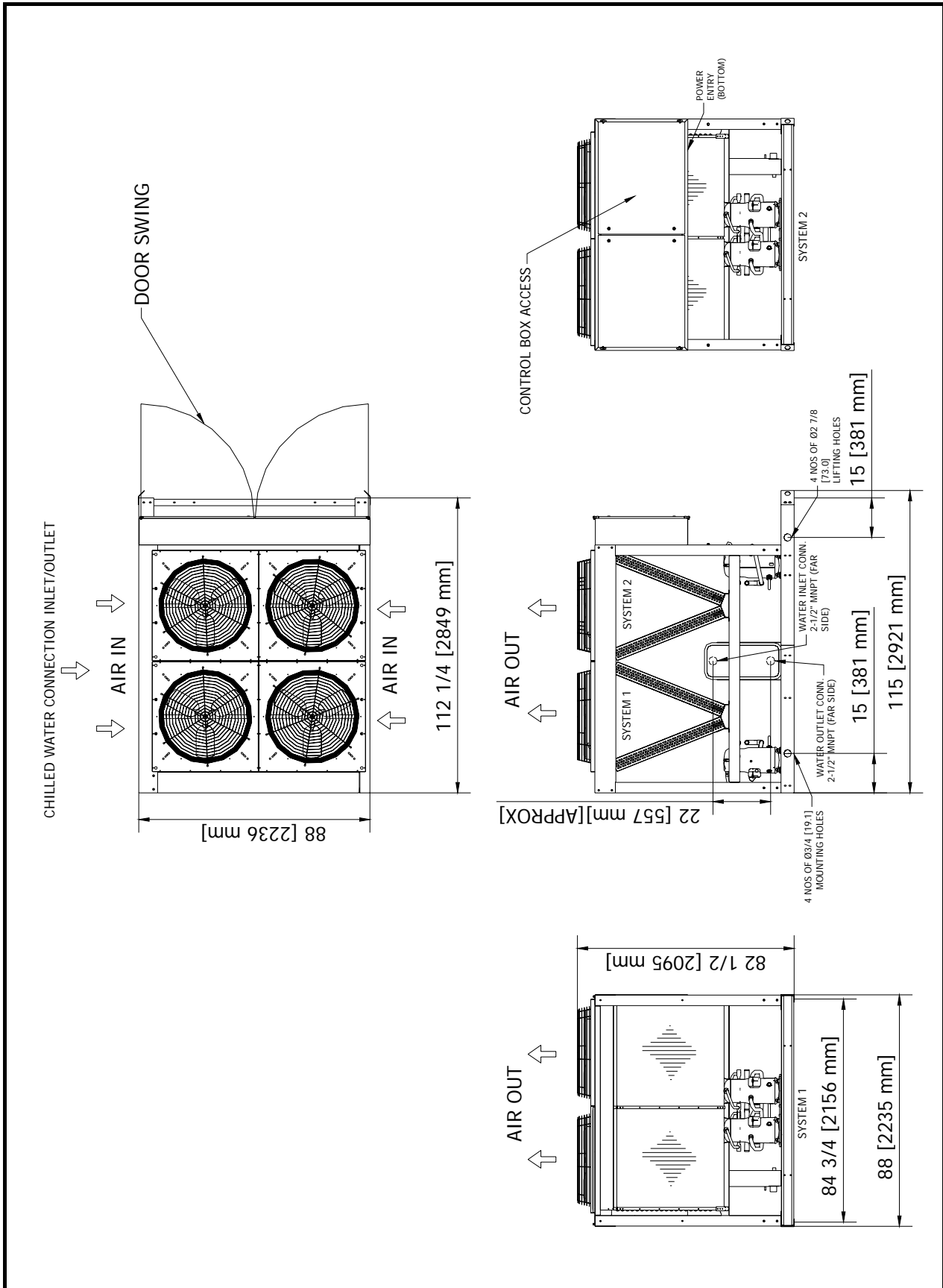

# DIMENSIONAL DATA

ACDS 050, 060, 070

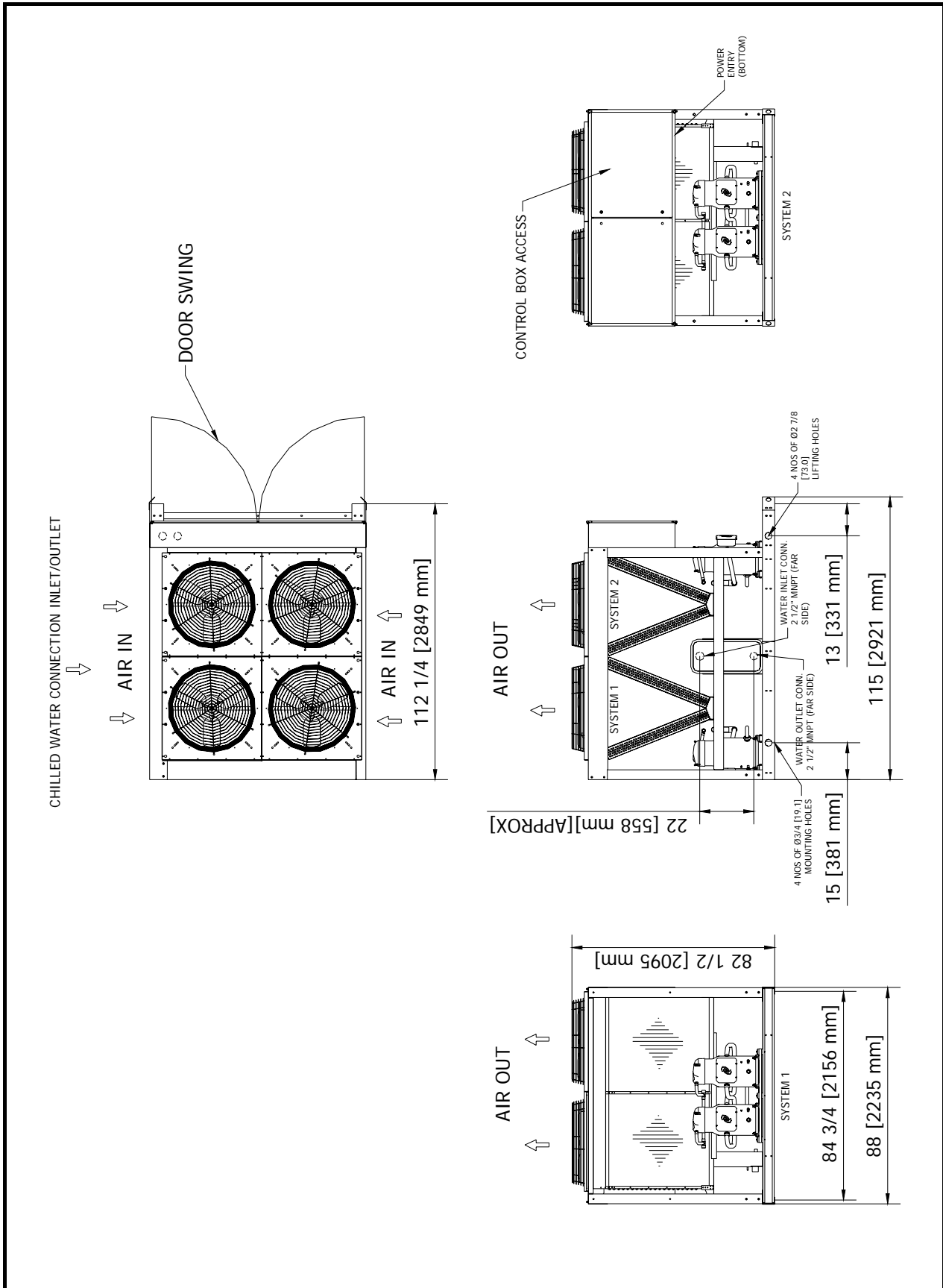

# DIMENSIONAL DATA

## ACDS 080, 090

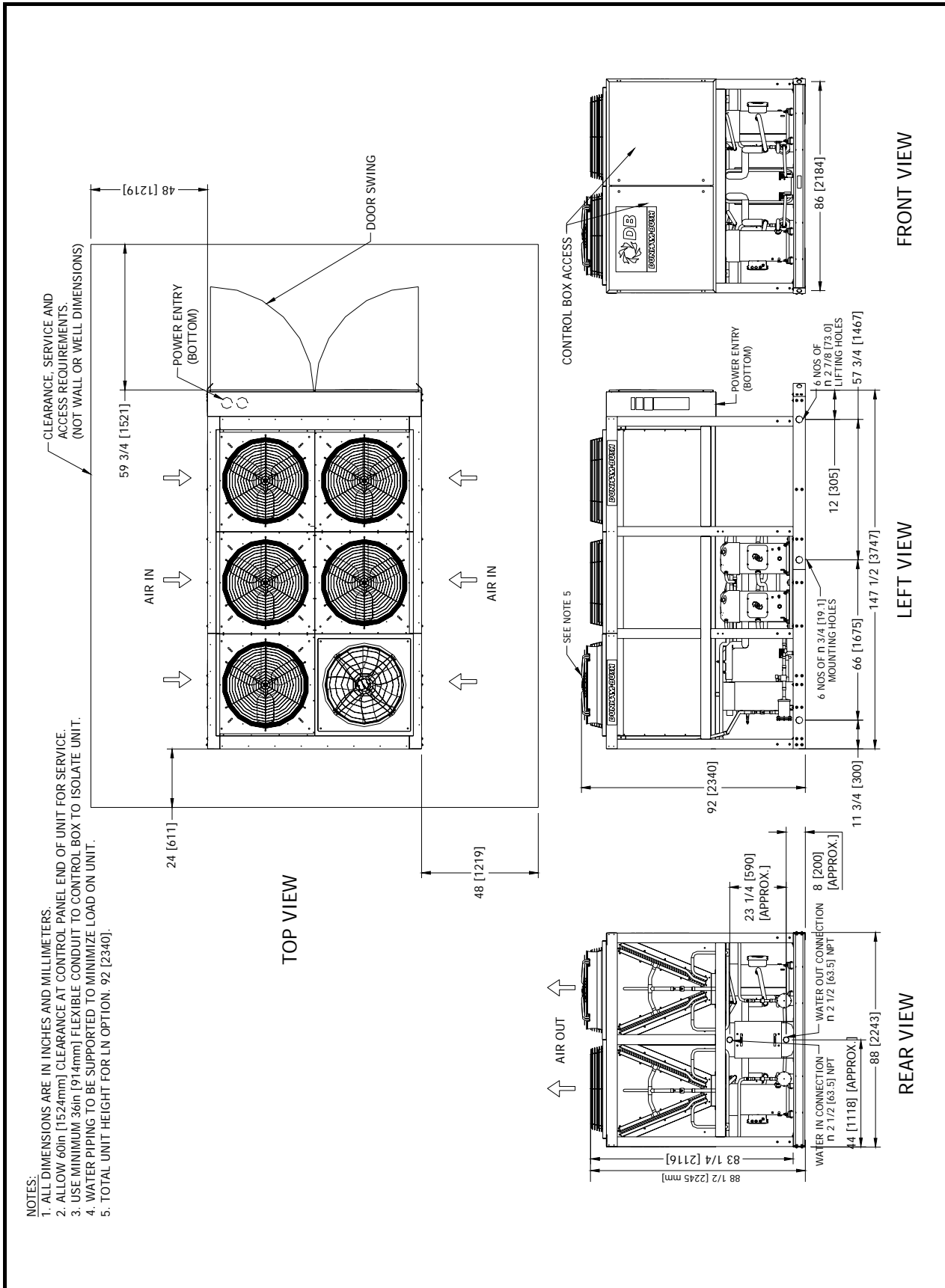

# DIMENSIONAL DATA

## ACDS 100, 120

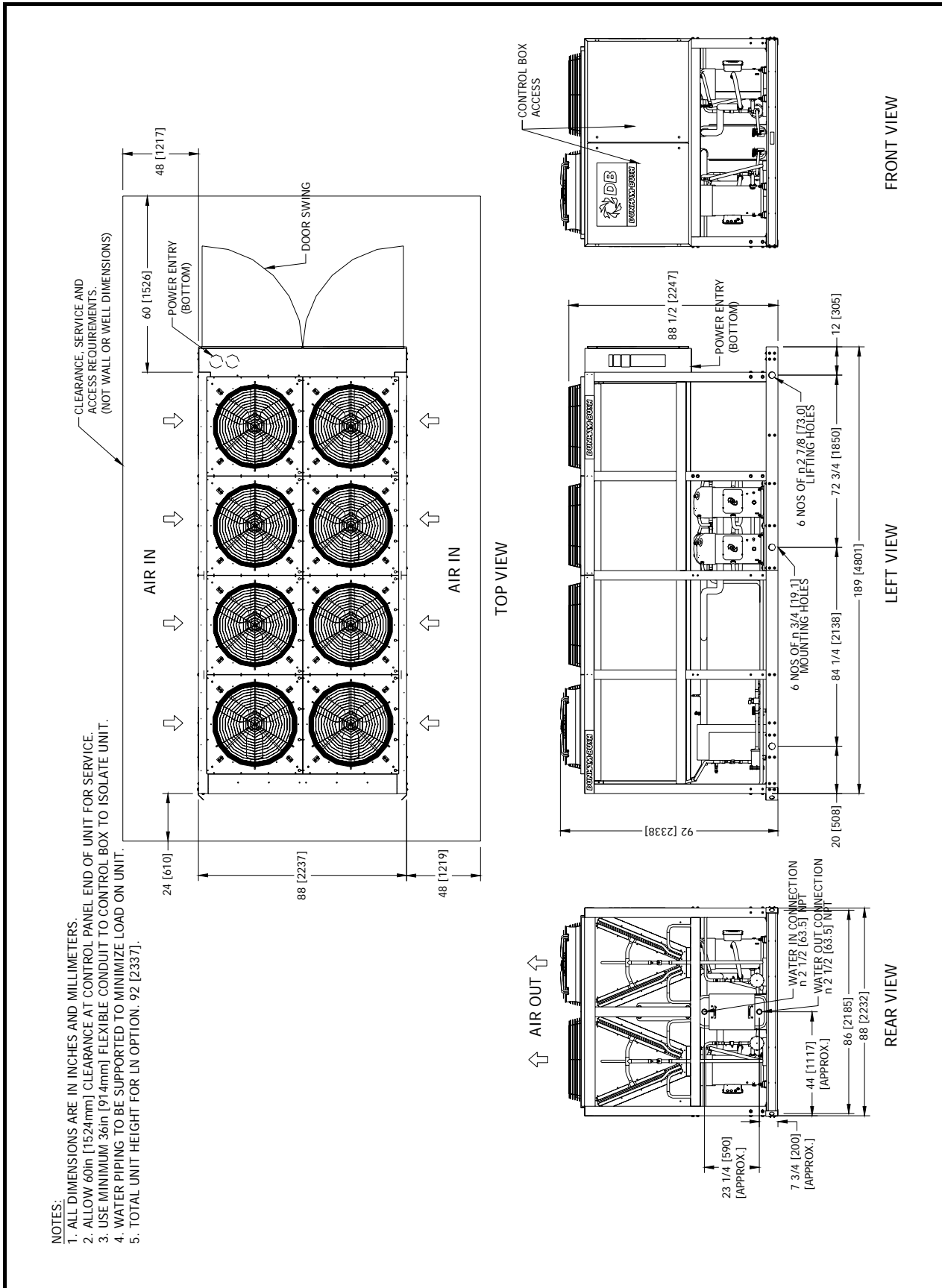

# DIMENSIONAL DATA

## ACDS 135, 150

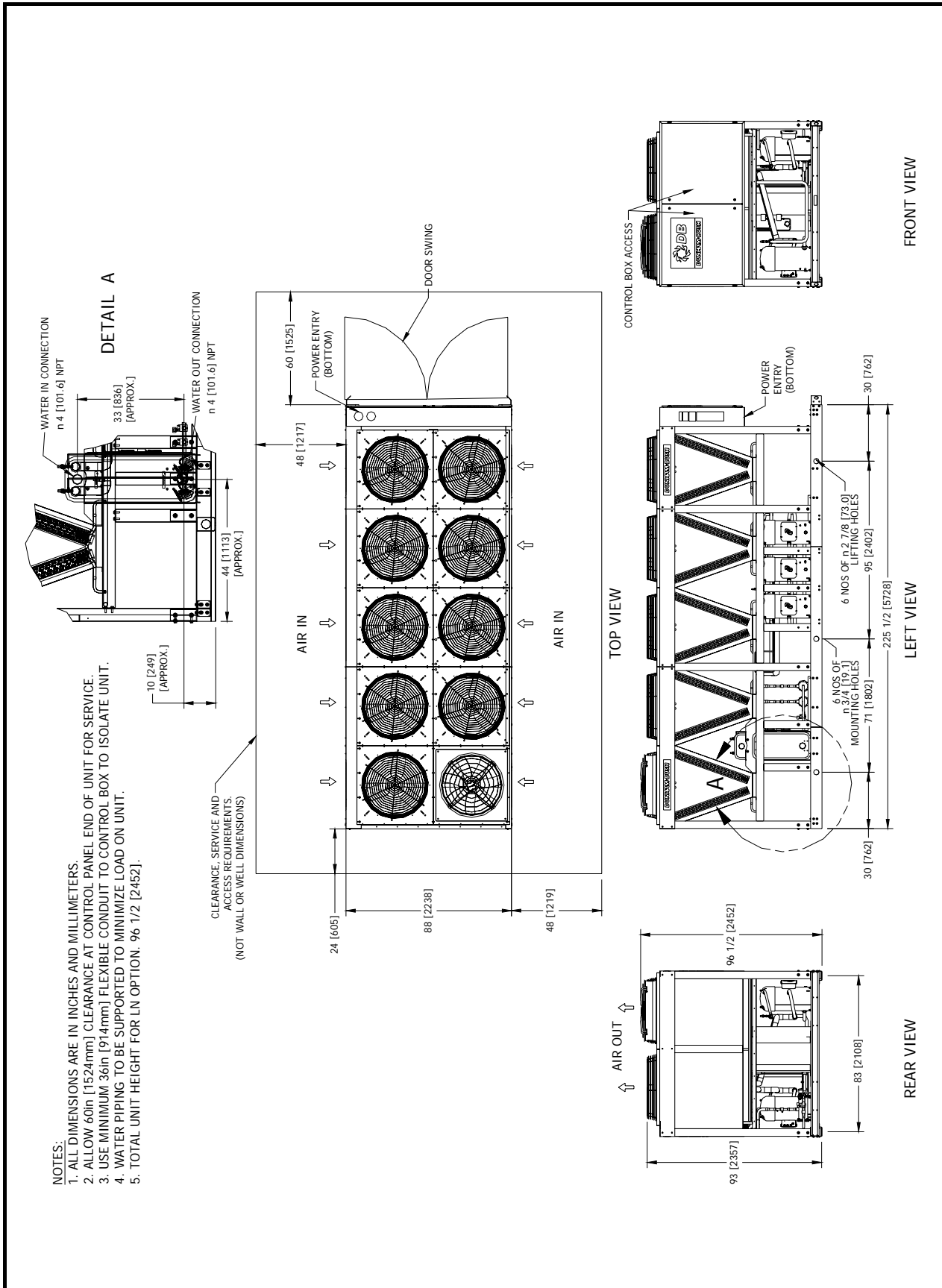

# DIMENSIONAL DATA

## ACDS 165, 180

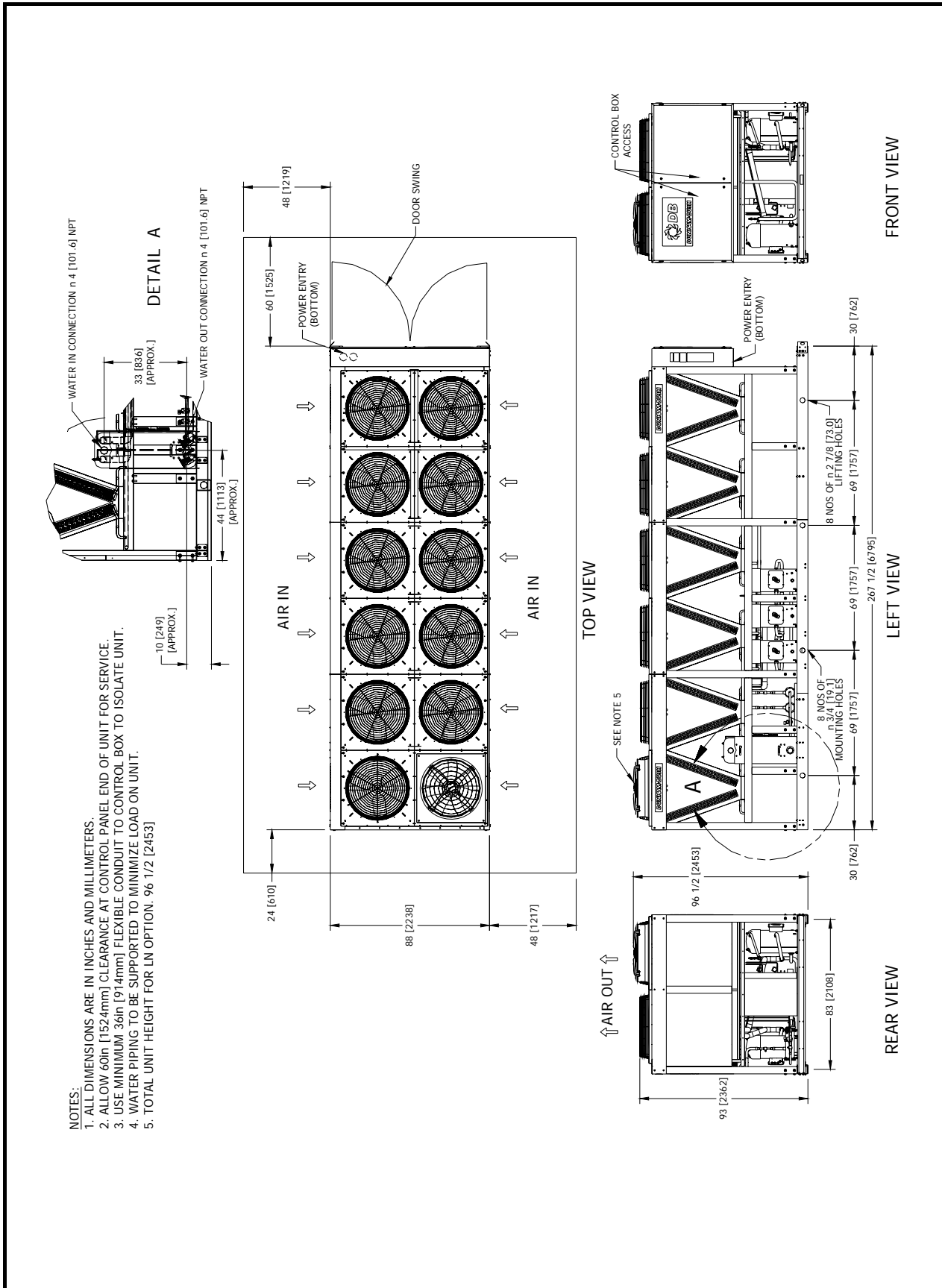

# FLOOR LOADING DIAGRAM

**ACDS 010**

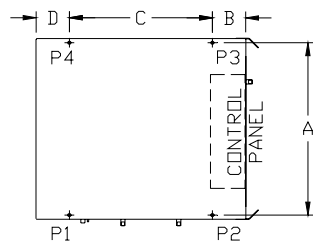

**ACDS 020, 030**

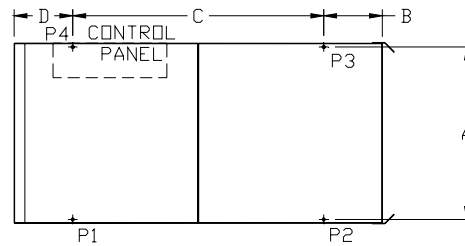

**ACDS 040, 050, 060, 070**

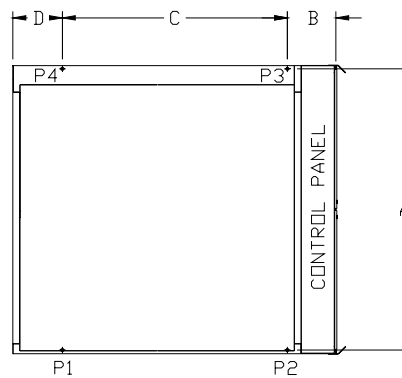

**ACDS 080, 090, 100, 120, 135, 150**

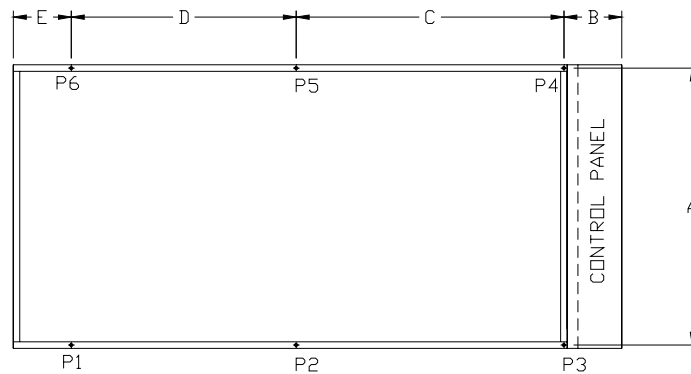

**ACDS 165, 180**

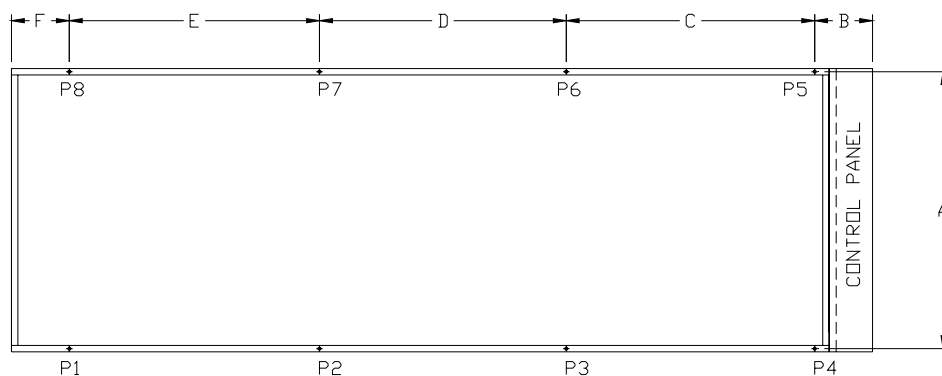



# FLOOR LOADING DIAGRAM

## POINT LOAD LOCATION

MODEL ACDS	Dimensions – inches [mm]					
	A	B	C	D	E	F
010	40 3/4 [1035]	8 [203]	34 1/4 [870]	8 [203]	-	-
020	46 [1168]	14 1/4 [362]	64 [1628]	11 3/4 [300]	-	-
030	49 3/4 [1262]	14 1/4 [362]	64 [1628]	11 3/4 [300]	-	-
040	84 3/4 (2156)	15 1/2 (393)	68 3/4 (1747)	15 (381)	-	-
050	84 3/4 (2156)	15 1/2 (393)	68 3/4 (1747)	15 (381)	-	-
060	84 3/4 (2156)	15 1/2 (393)	68 3/4 (1747)	15 (381)	-	-
070	84 3/4 (2156)	15 1/2 (393)	68 3/4 (1747)	15 (381)	-	-
080	86 [2184]	12 [305]	57 3/4 [1467]	66 [1675]	11 3/4 [300]	-
090	86 [2184]	12 [305]	57 3/4 [1467]	66 [1675]	11 3/4 [300]	-
100	86 [2184]	12 [305]	73 [1850]	84 [2138]	20 [508]	-
120	86 [2184]	12 [305]	73 [1850]	84 [2138]	20 [508]	-
135	83 [2108]	30 [762]	95 [2402]	71 [1802]	30 [762]	-
150	83 [2108]	30 [762]	95 [2402]	71 [1802]	30 [762]	-
165	83 [2108]	30 [762]	69 [1757]	69 [1757]	69 [1757]	30 [762]
180	83 [2108]	30 [762]	69 [1757]	69 [1757]	69 [1757]	30 [762]

## POINT LOAD DATA

MODEL ACDS	Loads - lbs [kg]								Total Operating Weight lbs [kg]
	P1	P2	P3	P4	P5	P6	P7	P8	
010	181 [82]	252 [114]	279 [126]	223 [101]	-	-	-	-	934 [424]
020	315 [143]	406 [184]	558 [253]	390 [178]	-	-	-	-	1669 [757]
030	455 [206]	660 [299]	826 [375]	481 [218]	-	-	-	-	2422 [1099]
040	728 [330]	793 [360]	802 [364]	734 [333]	-	-	-	-	3056 [1386]
050	823 [373]	933 [423]	947 [430]	832 [377]	-	-	-	-	3535 [1603]
060	875 [397]	964 [437]	978 [444]	884 [401]	-	-	-	-	3700 [1678]
070	913 [414]	982 [446]	996 [452]	922 [418]	-	-	-	-	3813 [1730]
080	836 [379]	819[372]	804[365]	804[365]	819[372]	836 [379]	-	-	4918 [2231]
090	904 [410]	881 [400]	860 [390]	860 [390]	881 [400]	904 [410]	-	-	5290 [2400]
100	1026 [465]	1043 [473]	1064 [482]	1064 [482]	1043 [473]	1026 [465]	-	-	6264 [2841]
120	1049 [476]	1063 [482]	1080 [490]	1080 [490]	1063 [482]	1049 [476]	-	-	6383 [2865]
135	1137 [516]	1242 [564]	1348 [611]	1348 [611]	1242 [564]	1137 [516]	-	-	7454 [3381]
150	1225 [556]	1334 [605]	1443 [655]	1443 [655]	1334 [605]	1225 [556]	-	-	8005 [3631]
165	1110 [504]	1141 [518]	1172 [532]	1202 [545]	1202 [545]	1172 [532]	1141 [518]	1110 [504]	9251 [4196]
180	1225 [556]	1242 [564]	1260 [571]	1277 [579]	1277 [579]	1260 [571]	1242 [564]	1225 [556]	10007 [4539]

# EVAPORATOR WATER PRESSURE DROP

## 1a.) IMPERIAL UNITS

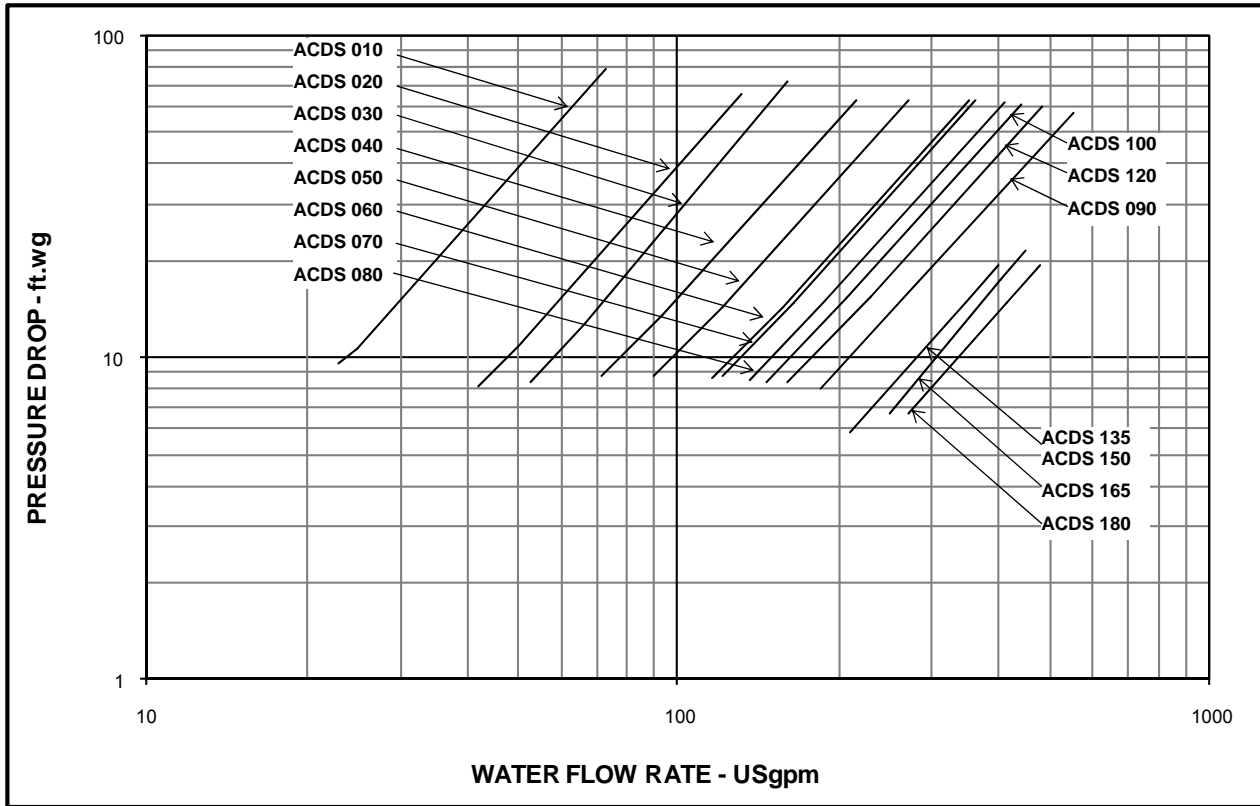

## 1b.) SI UNITS

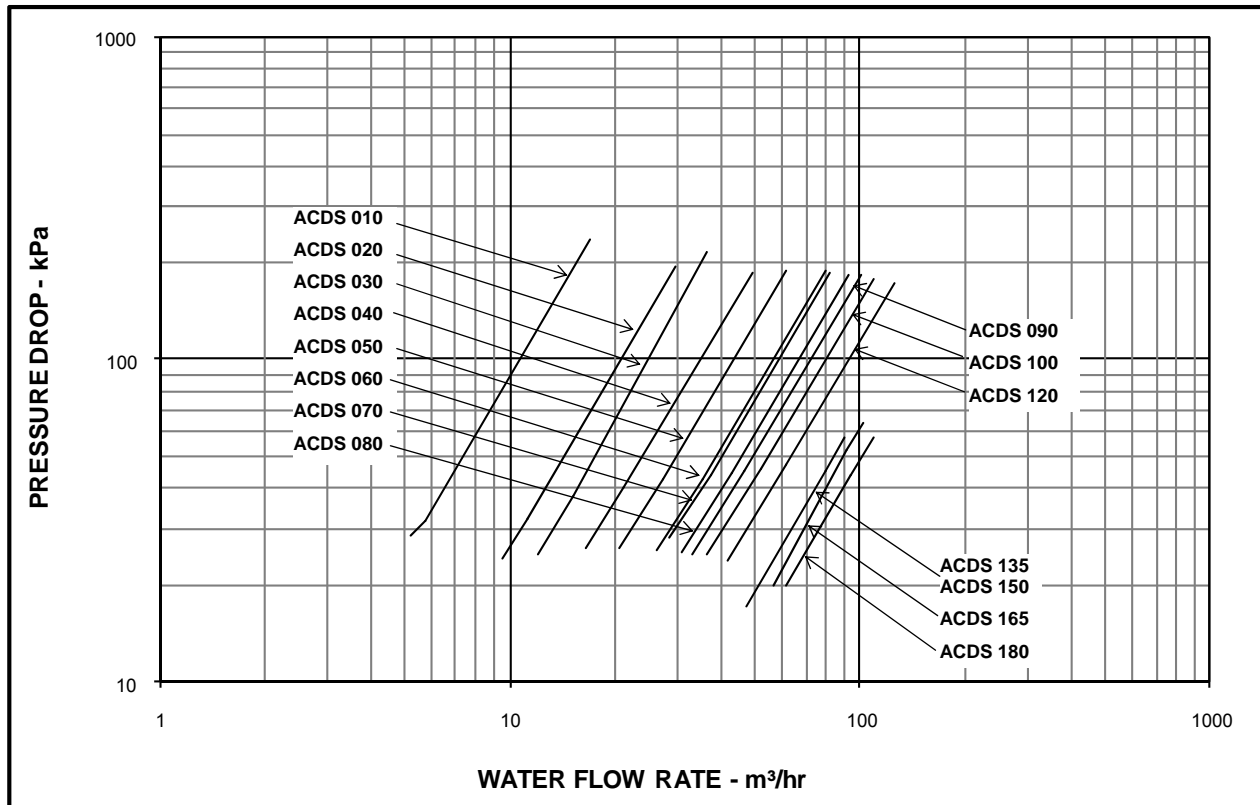

# CONDENSER FAN

## FAN POSITION NUMBER & CYCLING SEQUENCE

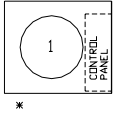
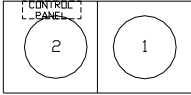
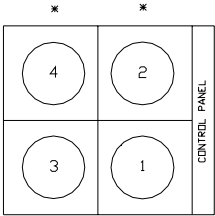
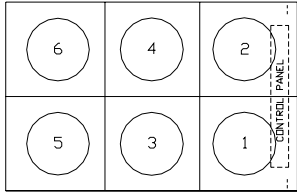
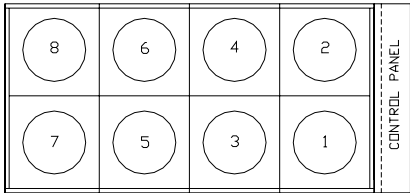
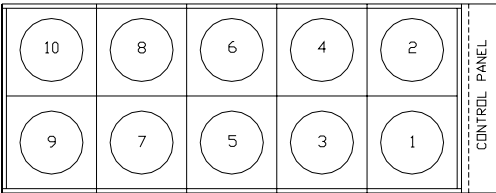
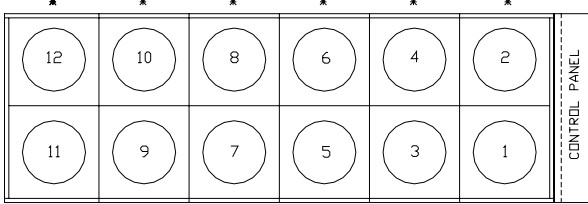
<b>ACDS 010</b> 		<b>ACDS 020, 030</b> 																									
<table border="1"> <tr> <td>Base Fans</td> <td>1</td> </tr> </table>		Base Fans	1	<table border="1"> <tr> <td>Base Fans</td> <td colspan="2">1</td> </tr> <tr> <td>Stage 2</td> <td colspan="2">2</td> </tr> </table>		Base Fans	1		Stage 2	2																	
Base Fans	1																										
Base Fans	1																										
Stage 2	2																										
<b>ACDS 040, 050, 060, 070</b> 		<b>ACDS 080, 090</b> 																									
<table border="1"> <tr> <td></td> <td><b>System 1</b></td> <td><b>System 2</b></td> </tr> <tr> <td>Base Fans</td> <td>4</td> <td>2</td> </tr> <tr> <td>Stage 2</td> <td>3</td> <td>1</td> </tr> </table>			<b>System 1</b>	<b>System 2</b>	Base Fans	4	2	Stage 2	3	1	<table border="1"> <tr> <td></td> <td><b>System 1</b></td> <td><b>System 2</b></td> </tr> <tr> <td>Base Fans</td> <td>6</td> <td>5</td> </tr> <tr> <td>Stage 2</td> <td>4</td> <td>3</td> </tr> <tr> <td>Stage 3</td> <td>2</td> <td>1</td> </tr> </table>			<b>System 1</b>	<b>System 2</b>	Base Fans	6	5	Stage 2	4	3	Stage 3	2	1			
	<b>System 1</b>	<b>System 2</b>																									
Base Fans	4	2																									
Stage 2	3	1																									
	<b>System 1</b>	<b>System 2</b>																									
Base Fans	6	5																									
Stage 2	4	3																									
Stage 3	2	1																									
<b>ACDS 100, 120</b> 		<b>ACDS 135, 150</b> 																									
		Note: Based on highest discharge pressure between 2 systems.																									
<table border="1"> <tr> <td></td> <td><b>System 1</b></td> <td><b>System 2</b></td> </tr> <tr> <td>Base Fans</td> <td>8</td> <td>7</td> </tr> <tr> <td>Stage 2</td> <td>6</td> <td>5</td> </tr> <tr> <td>Stage 3</td> <td>2, 4</td> <td>1, 3</td> </tr> </table>			<b>System 1</b>	<b>System 2</b>	Base Fans	8	7	Stage 2	6	5	Stage 3	2, 4	1, 3	<table border="1"> <tr> <td></td> <td><b>System 1</b></td> <td><b>System 2</b></td> </tr> <tr> <td>Base Fans</td> <td>8, 10</td> <td>2, 4, 6</td> </tr> <tr> <td>Stage 2</td> <td>7, 9</td> <td>1, 3</td> </tr> <tr> <td>Stage 3</td> <td>5</td> <td>2</td> </tr> </table>			<b>System 1</b>	<b>System 2</b>	Base Fans	8, 10	2, 4, 6	Stage 2	7, 9	1, 3	Stage 3	5	2
	<b>System 1</b>	<b>System 2</b>																									
Base Fans	8	7																									
Stage 2	6	5																									
Stage 3	2, 4	1, 3																									
	<b>System 1</b>	<b>System 2</b>																									
Base Fans	8, 10	2, 4, 6																									
Stage 2	7, 9	1, 3																									
Stage 3	5	2																									
<b>ACDS 165, 180</b> 																											
<table border="1"> <tr> <td></td> <td><b>System 1</b></td> <td><b>System 2</b></td> </tr> <tr> <td>Base Fans</td> <td>8, 10, 12</td> <td>2, 4, 6</td> </tr> <tr> <td>Stage 2</td> <td>7, 11</td> <td>1, 5</td> </tr> <tr> <td>Stage 3</td> <td>9</td> <td>3</td> </tr> </table>			<b>System 1</b>	<b>System 2</b>	Base Fans	8, 10, 12	2, 4, 6	Stage 2	7, 11	1, 5	Stage 3	9	3														
	<b>System 1</b>	<b>System 2</b>																									
Base Fans	8, 10, 12	2, 4, 6																									
Stage 2	7, 11	1, 5																									
Stage 3	9	3																									

\*Coil Header

# SOUND PRESSURE DATA

MODEL	OCTAVE BAND (Hz)								TOTAL dB (A)
	63	125	250	500	1K	2K	4K	8K	
<b>1. FOR STANDARD UNIT</b>									
ACDS 010*GS	30	35	45	49	50	48	45	40	55
ACDS 020*GS	33	38	47	52	53	54	48	43	59
ACDS 030*GS	33	38	47	54	55	53	49	43	60
ACDS 040*GS	35	41	50	55	56	56	51	46	61
ACDS 050*GS	35	41	50	57	57	56	52	46	62
ACDS 060*GS	35	41	51	57	57	57	52	47	63
ACDS 070*GS	35	41	51	57	57	58	53	48	63
ACDS 080*GS	37	42	52	58	58	58	53	48	64
ACDS 090*GS	37	42	52	58	59	58	53	48	64
ACDS 100*GS	38	43	53	60	62	60	55	49	66
ACDS 120*GS	38	43	53	62	63	61	56	49	67
ACDS 135*GS	39	44	54	62	63	61	56	50	67
ACDS 150*GS	39	44	54	62	63	61	56	50	67
ACDS 165*GS	40	45	54	62	63	61	56	50	68
ACDS 180*GS	40	45	54	63	65	62	57	50	69
<b>2. FOR LOW NOISE FAN ONLY</b>									
ACDS 010*GF	24	37	41	45	47	45	40	34	51
ACDS 020*GF	26	40	44	48	51	52	44	37	56
ACDS 030*GF	26	40	44	52	53	51	46	39	57
ACDS 040*GF	29	43	47	50	53	55	46	40	59
ACDS 050*GF	29	43	47	54	55	54	49	42	60
ACDS 060*GF	29	43	48	55	55	56	49	44	61
ACDS 070*GF	29	43	48	55	55	57	50	45	61
ACDS 080*GF	31	44	49	55	56	57	50	44	61
ACDS 090*GF	31	44	48	55	56	56	49	43	61
ACDS 100*GF	32	45	49	59	60	59	52	43	65
ACDS 120*GF	32	45	50	61	62	60	53	44	66
ACDS 135*GF	33	46	51	61	62	60	53	46	66
ACDS 150*GF	33	46	51	61	62	60	53	46	66
ACDS 165*GF	33	47	51	62	62	60	53	46	66
ACDS 180*GF	33	47	51	62	64	61	54	46	68
<b>3. FOR COMPRESSOR JACKET ONLY</b>									
ACDS 010*GV	30	35	45	49	50	48	45	40	55
ACDS 020*GV	33	38	47	52	53	52	48	43	58
ACDS 030*GV	33	38	47	52	53	51	48	43	58
ACDS 040*GV	35	41	50	54	56	54	51	46	61
ACDS 050*GV	35	41	50	55	56	54	51	46	61
ACDS 060*GV	35	41	50	55	56	54	51	46	61
ACDS 070*GV	35	41	50	55	56	55	51	46	61
ACDS 080*GV	37	42	52	56	57	56	52	47	62
ACDS 090*GV	37	42	52	56	57	56	52	47	62
ACDS 100*GV	38	43	53	57	59	57	54	48	64
ACDS 120*GV	38	43	53	57	59	57	54	48	64
ACDS 135*GV	39	44	54	58	59	58	54	49	64
ACDS 150*GV	39	44	54	58	59	58	54	49	64
ACDS 165*GV	40	45	54	59	60	59	55	50	65
ACDS 180*GV	40	45	54	59	61	59	55	50	65
<b>4. FOR LOW NOISE FAN + COMPRESSOR JACKET</b>									
ACDS 010*GM	24	37	41	45	47	45	39	34	51
ACDS 020*GM	26	40	44	47	50	48	42	36	54
ACDS 030*GM	26	40	44	47	50	48	43	36	54
ACDS 040*GM	29	43	47	50	52	51	45	39	57
ACDS 050*GM	29	43	47	50	53	51	45	39	57
ACDS 060*GM	29	43	47	50	53	51	45	39	57
ACDS 070*GM	29	43	47	50	53	51	45	39	57
ACDS 080*GM	31	44	48	52	54	53	47	41	59
ACDS 090*GM	31	44	48	52	54	53	47	41	59
ACDS 100*GM	32	45	49	53	56	54	48	42	60
ACDS 120*GM	32	45	49	53	57	55	48	42	61
ACDS 135*GM	33	46	50	54	56	55	49	43	61
ACDS 150*GM	33	46	50	54	56	55	49	43	61
ACDS 165*GM	33	47	51	55	57	56	50	43	62
ACDS 180*GM	33	47	51	55	58	56	50	43	62

\* Refer voltage AN, AR & AG.

Note: Unit Sound Pressure Level (Lp) @ 30 FT [9m] (free field), ± 2 dB tolerance.



# TYPICAL WIRING DIAGRAM

## ACDS (With IR33)

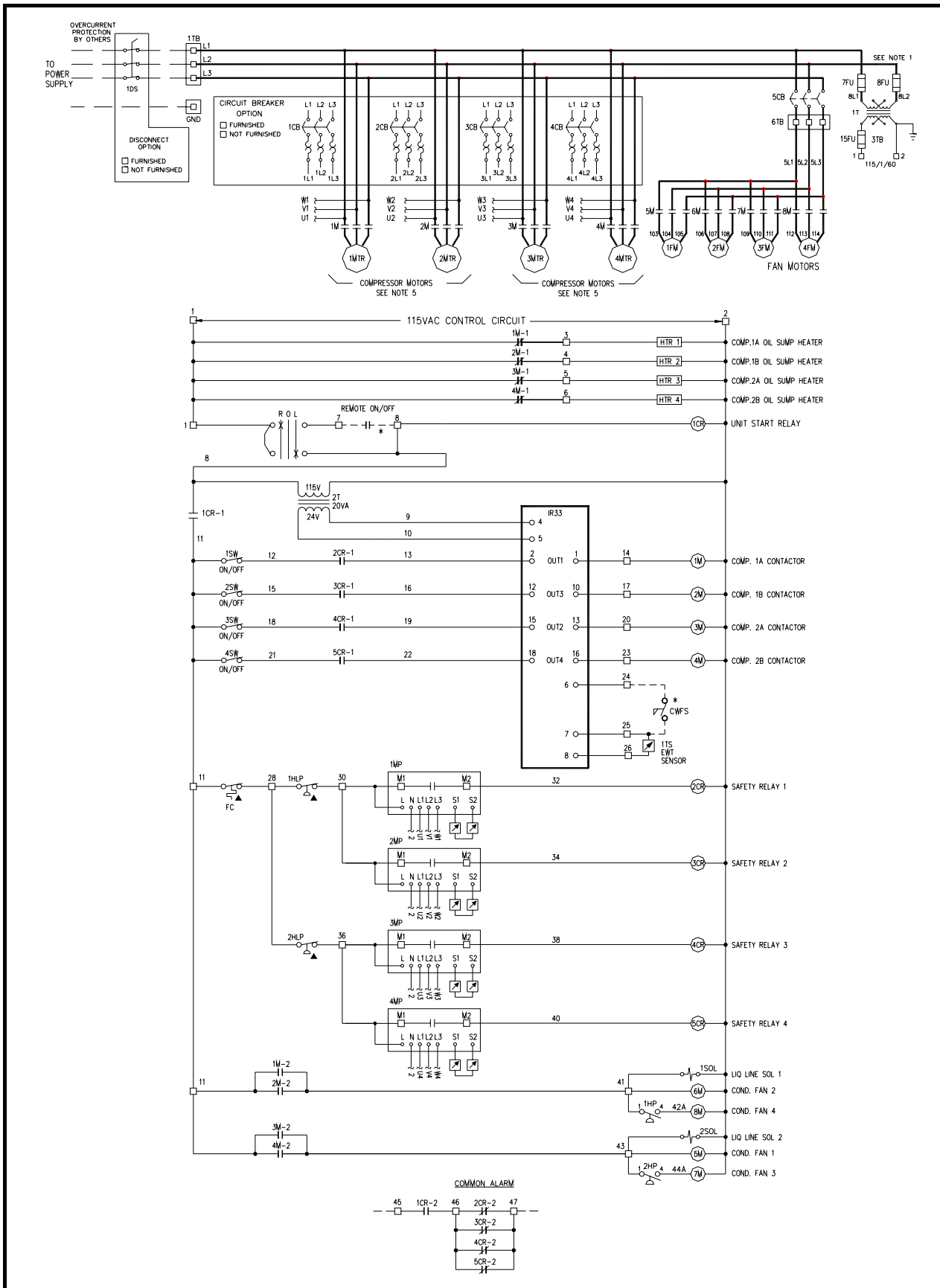

# TYPICAL WIRING DIAGRAM

## ACDS (With Vision2020i)

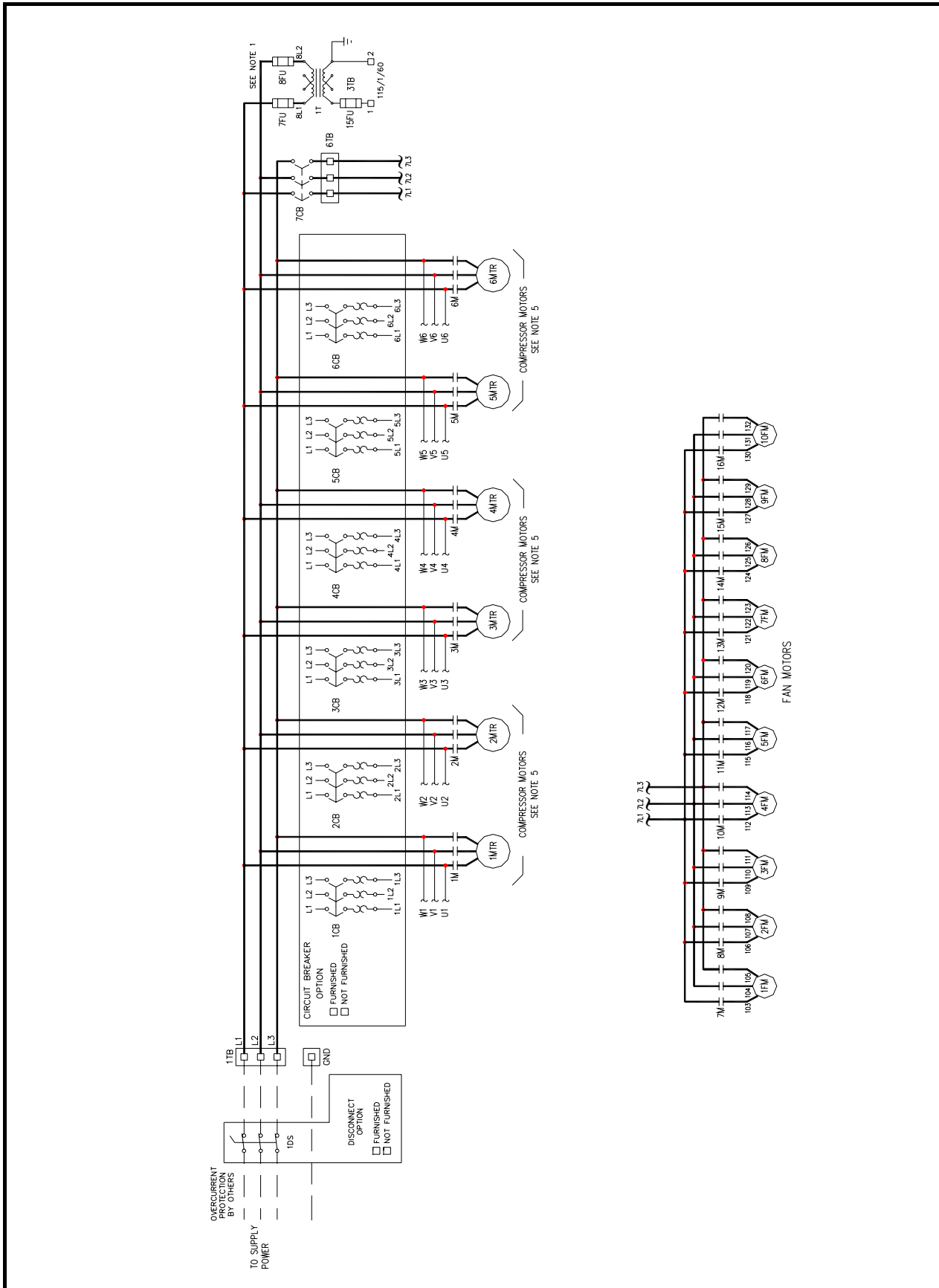

# TYPICAL WIRING DIAGRAM

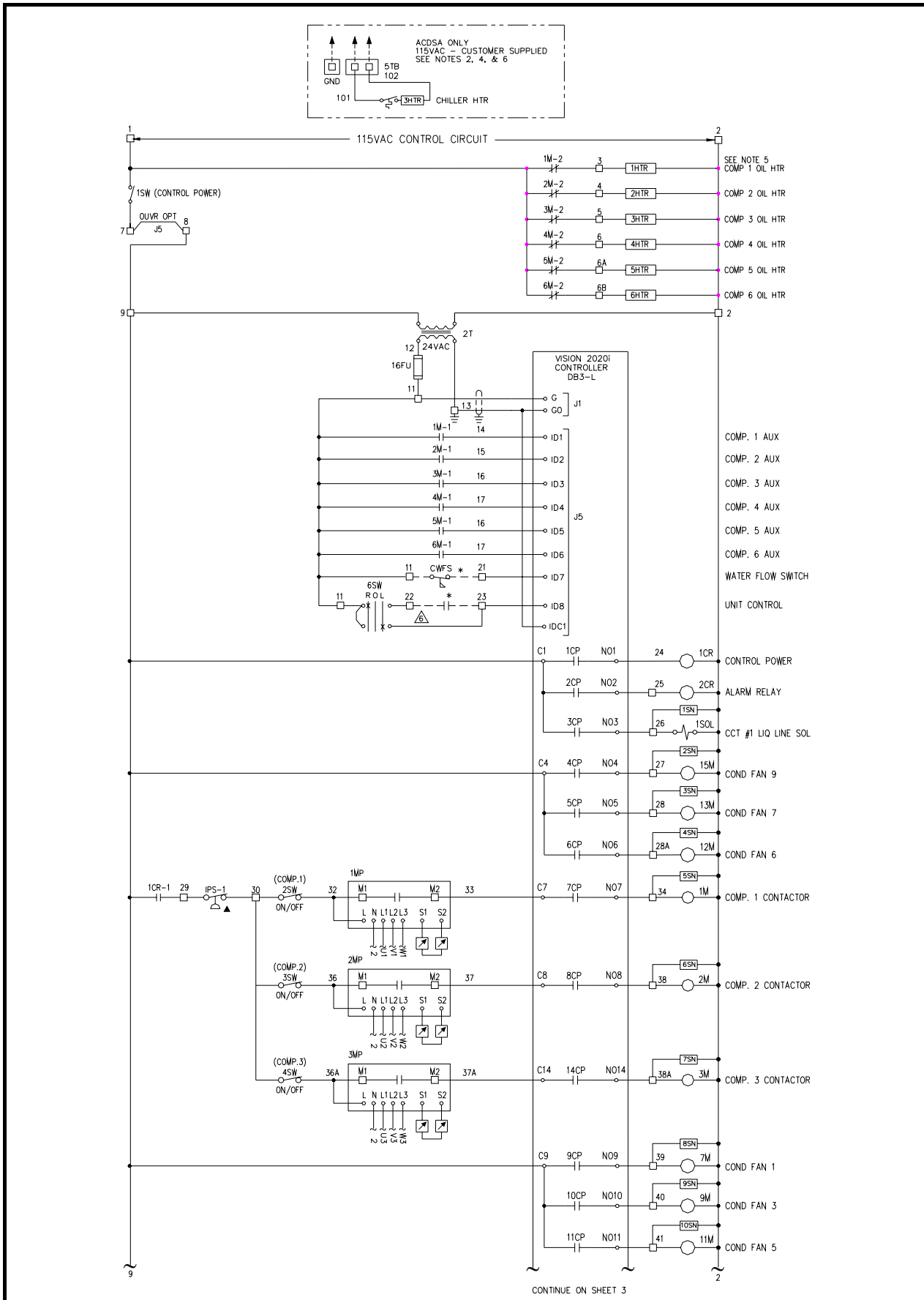

# TYPICAL WIRING DIAGRAM

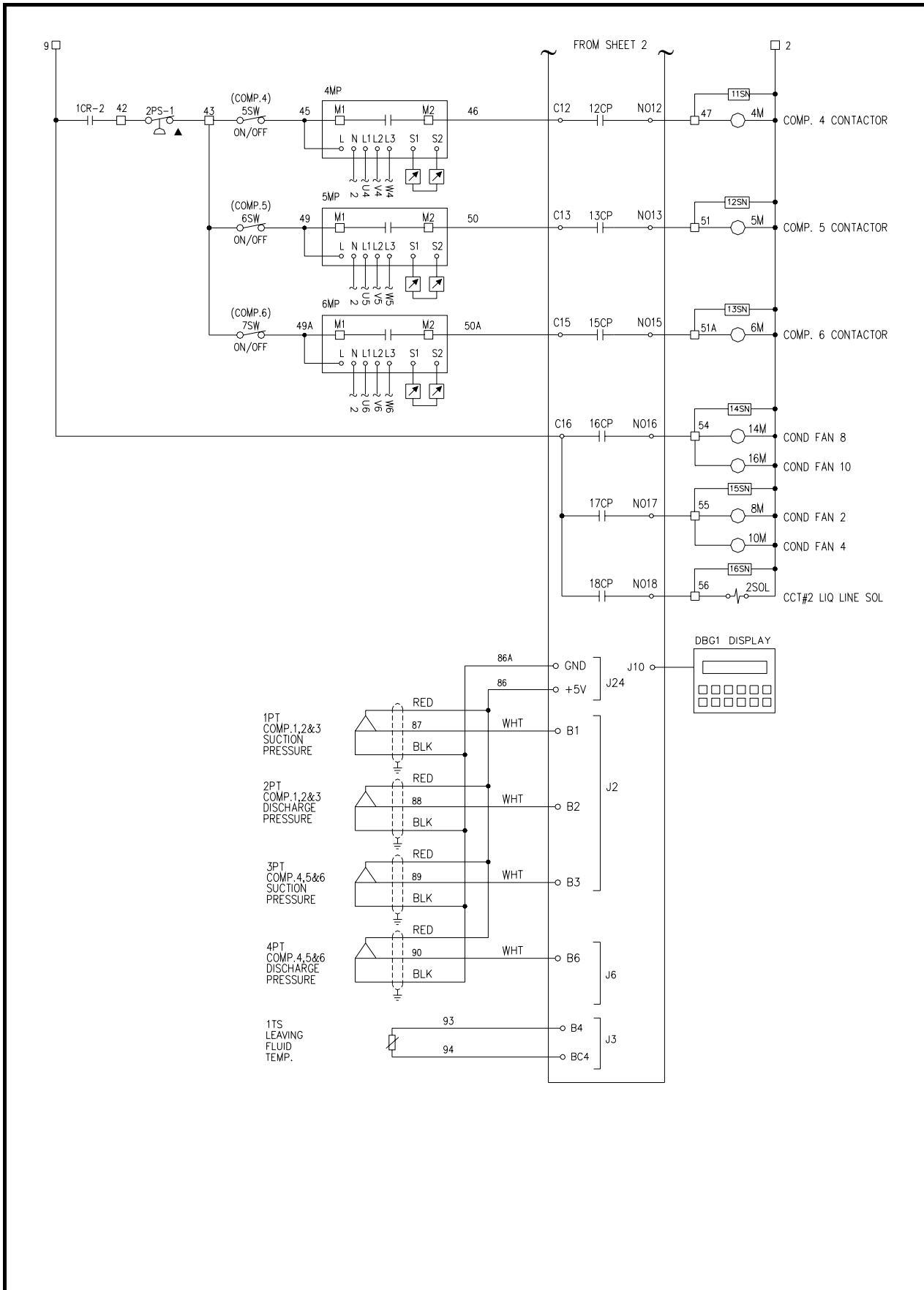

# TYPICAL WIRING DIAGRAM

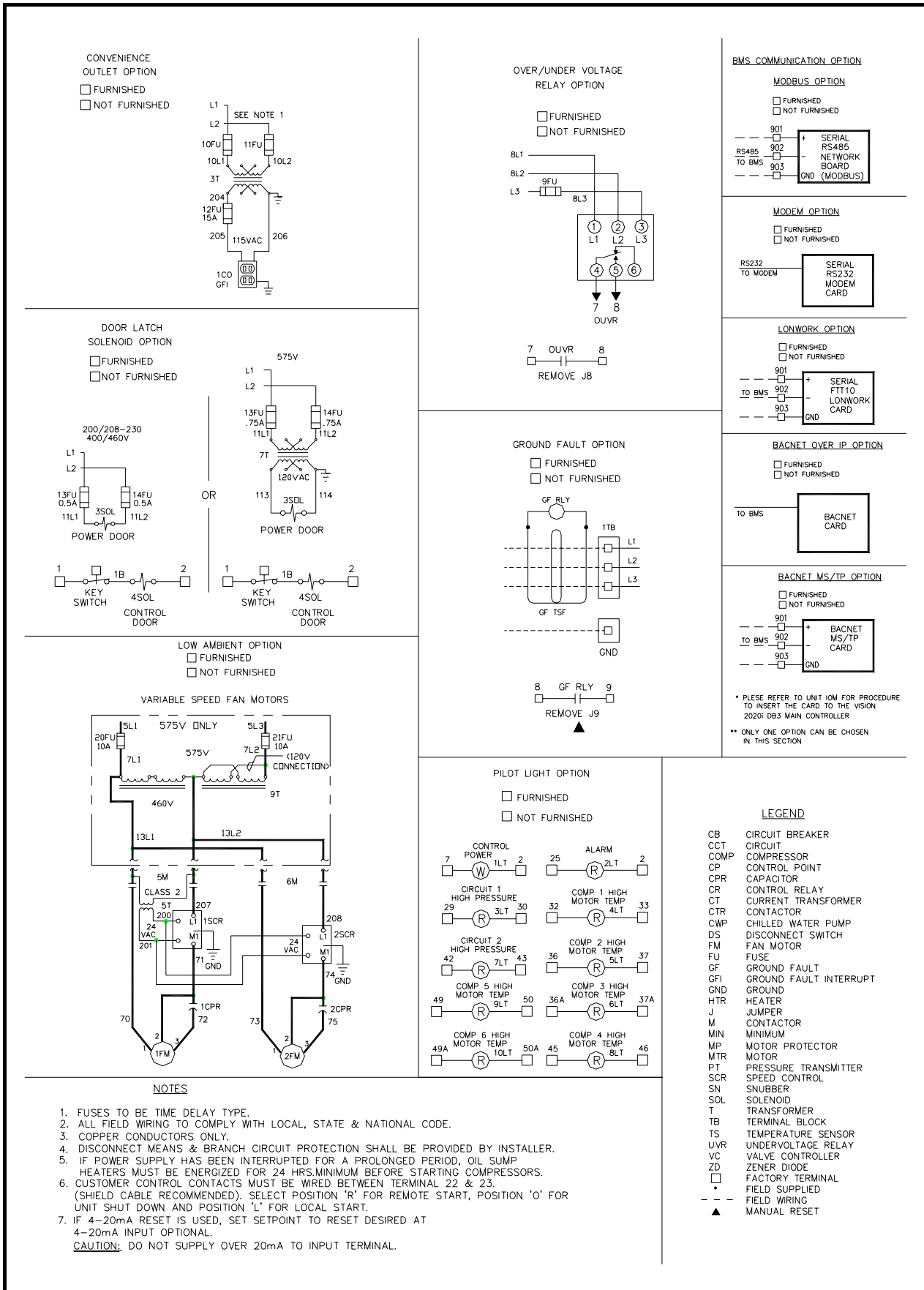

# GUIDE SPECIFICATIONS

---

## 1.0 GENERAL

### 1.1 Work Included

Provide complete electrically or microcomputer controlled air cooled chiller utilizing tandem or trio scroll compressor sets suitable for outdoor installation. Contractor will furnish and install chillers as shown and scheduled on the drawings. Units will be installed in accordance with this specification.

### 1.2 Quality Assurance

- A. Unit will be rated in accordance with AHRI Standard 550/590-2003.
- B. Unit construction will be designed to conform to ANSI/ASHRAE 15 latest version safety standards, NEC (USA), and ASME Section VIII (USA) applicable codes.
- C. Unit efficiency will meet or exceed ASHRAE Standard 90.1 (1989).
- D. Unit will have ETLc (USA) and (Canadian) approval (60Hz).
- E. The unit will be fully tested at the factory.

### 1.3 Design Base

- A. The construction drawings indicate a system based on a selected manufacturer of equipment and the design data available to the Engineer during construction document preparation. Electrical services, size, configuration and space allocations are consistent with that manufacturer's recommendations and requirements.
- B. Other listed or approved manufacturers are encouraged to provide equipment on this project; however, it will be the Contractor and/or Supplier's responsibility to assure the equipment is consistent with the design base. No compensation will be approved for revisions required by the design base or other manufacturers for any different services, space, clearances, etc.

### 1.4 Delivery And Handling

- A. The unit will be delivered to the job site completely assembled and charged with R410A refrigerant and oil by the manufacturer.
- B. Comply with the manufacturer's instruction for rigging and handling.

### 1.5 Maintenance

Maintenance of the chillers will be the responsibility of the owner and performed in accordance with the manufacturer's instructions.

## 2.0 PRODUCTS

### 2.1 Tandem or Trio Scroll Compressor Air Cooled Water Chillers

### 2.2 Acceptable Manufacturers

- A. Dunham-Bush
- B. (Approved equal)

### 2.3 General

- A. Furnish and install as shown on the plans, air cooled tandem or trio scroll compressor water chillers. Units will be Dunham-Bush Model ACDS or equal.
- B. The units are to be completely factory assembled and wired in a single package complete with tandem or trio scroll compressors, evaporator, condenser, starting control with safety and operating controls. The unit is to be given a complete factory operating and control sequence test under load conditions and is to be shipped with full operating charge of R410A and full oil charge.

### 2.4 Performance

The units will be furnished as shown on capacity schedules and drawings. Unit performance will be in accordance with AHRI Standard 550/590-2003.

### 2.5 Construction

The unit will be designed for maximum corrosion protection being of heavy gauge, galvanized steel construction with baked on powder coating.

### 2.6 Evaporator

Evaporator will be direct expansion, brazed plate heat exchanger. Fluid side design working pressure will be minimum 400psig [28bar] and refrigerant side design working pressure will be minimum 450psig [31bar]. Evaporator will be insulated with 3/4 inches [19mm] closed-cell insulation.

### 2.7 Condenser

The condenser coil is to be constructed of copper tubes and die-formed aluminum fins having self-spacing collars. Fins will be mechanically bonded to the tubes. Integral sub-cooling circuits will be incorporated into the coil. Condenser divider baffles will fully separate each condenser fan section to control the airflow to maintain proper head pressure control.

### 2.8 Fans

The fans will be heavy duty, aluminum blade, direct drive propeller type. Motors will be three phase (except for low ambient option lead fan per circuit) with internal overloads and are to be permanently lubricated.

# GUIDE SPECIFICATIONS

---

## 2.9 Compressor

- A. The compressors will be Tandem or Trio Scroll with suction and discharge manifolded and oil and gas equalization provided. All compressors will be 3500 RPM direct drive with an integral two-pole hermetic squirrel cage motor. A dust-proof terminal box, located in an accessible location on the compressor, will contain all connection terminals.
- B. The compressors will be fitted with a crankcase heater, and oil sight glass.

## 2.10 Capacity Control

Compressor cycling will be utilized to match the demand requirement of the system. A Proactive Full function Vision 2020i controller will cycle compressors in response to leaving fluid temperature and maintain fluid temperature within 3.0°F [1.7°C] of setpoint. This system is to provide precise and stable control of supply fluid temperature over the complete range of operating conditions. It will be capable of a system capacity range from 100% to \_\_\_\_\_ % at specified conditions without hot gas bypass.

## 2.11 Refrigerant Circuit

- A. (Two compressors)(Four compressors) (Six compressors) will be used with a direct expansion evaporator.
- B. Insulate evaporator and other cold surfaces as required to prevent condensation at ambient conditions of 75% humidity of 90°F [32°C] wet bulb with no air movement.
- C. Each refrigerant circuit will include expansion valve, sight glass, moisture indicator, solenoid valve, replaceable core filter-drier, liquid line shut off valves, and charging.

## 2.12 Control Center

- A. Control Center will be fully enclosed in a steel, baked powder coated, control panel with hinged access doors. Dual compartments, separating safety and operating controls from the power controls, are to be provided. Controls will include:
  - 1. Compressor protection, solid state, thermal sensing overloads, with manual reset.
  - 2. High refrigerant discharge pressure, manual reset.
  - 3. Separate power terminal blocks for main power and 115V AC chiller heater power.
  - 4. Compressor starter including current sensing overload protection.
  - 5. Software function development on PC Windows® based with factory installed sensors including integral anti-recycle protection (Optional for sizes 10- 70 TR).

- 6. Complete labeling of all control components.
  - 7. Numbered terminal strips and labeled components for easier wire tracing.
  - 8. Condenser pressure sensing fan cycling control for start-up and operation down to 30 °F [-1.1 °C].
- B. Control Center's individual Full Function Vision 2020i controller will provide compressor staging based on leaving fluid temperature. The Vision 2020i controller is design to work with a user friendly back-lit 132 by 64 pixels DBG1 Semi-Graphic Display panel connected with controller through telephone cable. The terminal allows carrying out all program operations. The user terminal allows displaying the unit working conditions, compressor run times, alarm history and modifying the parameters. The display also has an automatically self-test of the controller on system start-up. Multiple messages will be displayed by automatically scrolling from each message to the next. All of these messages are spelled out in English language on the display terminal.

There are 15 dedicated buttons enable user to access information, base on the security level of the password. The Vision 2020i will have an extended operating range of -77°F [-25°C] to +140°F [+60°C]. (It will be proactive in control and accommodate system anomalies such as high condenser pressure and high entering fluid temperature by controlling loading and refrigerant flow to keep the machine on line but at reduced capacity until the condition is corrected.)
  - C. Vision 2020i individual chiller controller will provide as a minimum the following features and options.
    - 1. Vision 2020i- Unit Control will provide the following capabilities:
      - a. Staging of compressors and hot gas bypass to achieve precise control of leaving water.
      - b. Switching of fans on the air cooled condenser to control head pressure
      - c. 7 day time clock with schedules for machine control.
      - d. Automatic pump-down before compressor stops and automatic pump out before liquid line opens on start-up.
      - e. Proactive control of compressor cycling and /or hot gas bypass to help prevent high pressure or low pressure trips.

# GUIDE SPECIFICATIONS

---

- f. Proactive control providing safeties for high pressure, low pressure and freeze protection, to eliminate nuisance trips.
  - g. Proactive compressor staging to eliminate overloading during start-up to reduce compressor cycling.
  - h. Continuous evaluation of sensors.
2. Vision 2020i - Unit Protection will provide the following:
- a. Low pressure cutout with Proactive safety.
  - b. High pressure cutout with Proactive safety.
  - c. Automatic re-start from power outage with event posting.
  - d. Battery backed-up real time clock and memory with over 10 years life and automatic recharge of lithium ion battery that requires no service.
  - e. Safeties for temporary shutdown as well as lockout protection that requires manual reset.
  - f. Freeze protection on leaving chilled fluid temperature.
  - g. Anti-recycle timing.
  - h. Sensor error.
  - i. Pump down -pump out failure.
3. Vision 2020i -Readouts will provide the following:
- a. Sensor inputs.
  - b. Leaving liquid temperature.
  - c. Entering liquid temperature.
  - d. Compressor ampere draw.
  - e. Suction pressure each circuit.
  - f. Discharge pressure each refrigerant circuit.
  - g. Unit control contacts.
  - h. Water flow switch.
  - i. Chilled liquid reset.
  - j. Digital Outputs.
  - k. Compressor control status.
  - l. Liquid line solenoid control status.
  - m. Condenser fan control status.
  - n. Alarm control status.
4. Vision 2020i - Setpoints will provide the following with proper authorization):
- a. High discharge pressure.
  - b. Low suction pressure.
  - c. Freeze protect temperature.
  - d. Leaving liquid temperature.
  - e. Control zone settings.
  - f. Fan condenser control.
  - g. Pump down -pump out settings.
  - h. Low suction circuit limiting.
  - i. High discharge circuit limiting.
  - j. Anti-recycle delay setting.
5. Vision 2020i - Alarm History will provide the following:
- a. The 100 most recent alarms can be identified.
  - b. Low suction pressure of all circuits.
  - c. High discharge pressure of all circuits
  - d. Freeze protection cutout.
  - e. Pump down -pump out failure of all circuits.
  - f. External shutdown of each compressor.
  - g. Communication failure.
  - h. Power failure.
6. Vision 2020i remote monitoring capabilities - will include a complete full function communication system through the following means:
- a. NetVisor Program  
The controller can be provided with optional RS232 or RS485 communications card and NETVISOR software for full graphical remote monitoring and controlled from a PC terminal and optional phone modem or Internet connection through local PC server. RS 485 communication can support up to 20 Vision 2020i station.
  - b. DB Link Program  
The controller also can be provided with optional RS485 communications card and DB Link program for simple local monitoring and controlled from a local PC terminal through RS485 to USB converter.
  - c. Building Management System (BMS) Interface  
With various optional add-on cards, Vision 2020i controller can be interfaced directly and easily to the BMS with the standard communication protocols using MODBUS, LONWORKS, BACNET MSTP or over IP.
  - d. Communication distance
    - i) RS232 via a (3) wire shielded cable up to 100 feet [30 meters].
    - ii) RS485 via a (2) wire shielded cable up to 4000 feet [1200 meters].
    - iii) Ethernet cable up to 330 feet [100 meters].

## 2.13 Starting Equipment

- A. Unit mounted contactors with compressor motor module protection for each compressor.
- B. Five (5)minute anti-recycle timer

# GUIDE SPECIFICATIONS

---

## 2.14 Optional Features

Certain standard features are not applicable when the features are specified – For assistance in amending the specifications, contact your Dunham-Bush representative.

1. Copper Fin/Copper Tube condenser coil.
2. Silicone polyester Poly-Coat condenser fin coating per ASME B117 specification for maximum salt spray and corrosion resistance.
3. Convenience Outlet 115 volt AC powered dual 3 prong ground fault receptacle powered by dedicated transformer and fused for 15 amps.
4. Hot gas bypass valve to permit operation down to 50% of unit mechanical unloading capability.
5. Low ambient control to 0°F [-17.8°C] minimum starting ambient.
6. Extra low ambient control to -20°F [-28°C] minimum starting ambient.
7. Low ambient lock-out control requiring a field setpoint.
8. Gauges include suction and discharge pressure for each refrigerant circuit in addition to the readings through the microcomputer.
9. Steel Painted Louvers for complete unit enclosure for general mechanical security and unit aesthetics.
10. Over and under voltage protection relay protects against high and low incoming voltage conditions as well as single phasing, phase reversal and phase imbalance.
11. Weatherproof Alarm Bell mounted and wired to indicate a common alarm fault.
12. Mounted and Wired Water Flow Switch.
13. Undervoltage and phase failure protection against low voltage, phase imbalance or phase reversal.
14. Operating and safety lights visible from unit exterior including:
  - a. Control Power on.
  - b. High pressure, high motor temperature and general alarm.
15. Control panel solenoid door latch to prevent door opening before turning off power to the unit.
16. Electronic expansion valves which will be controlled by Vision 2020i controller.
17. Control of Hot Gas bypass.
18. Chilled fluid pump control system.
19. Hot gas bypass status.
20. Ambient temperature.
21. Utility demand limit.
22. Chilled fluid pump control.
23. Electronic expansion valve.

24. High & low compressor amperes
25. Non-fused disconnect switch with through-the-door interlocking handle.
26. Unit mounted power transformer to provide 115 VAC control power.
27. Multiple small horsepower compressors for reduced inrush starting.
28. Ground fault interrupter.

## 3.0 EXECUTION

### 3.1 Installation Work By Mechanical Contractor

- A. Install on a flat surface level within 1/16 inches [1.6mm] and of sufficient strength to support concentrated loading. Place vibration isolators under the unit.
- B. Assemble and install all components furnished loose by manufacturer as recommended by the manufacturer's literature.
- C. Complete all fluid and electrical connections so unit, fluid circuits and electrical circuits are serviceable.
- D. Provide and install valves in fluid piping upstream and downstream of the evaporator to provide means of isolating shells for maintenance and to balance and trim system.
- E. Provide soft sound and vibration eliminator connections to the evaporator fluid inlet and outlet as well as electrical connections to the unit.
- F. Interlock chillers through a flow switch in the chilled fluid line to the chilled fluid pump to ensure the unit can operate only when fluid flow is established.
- G. Furnish and install taps for thermometers and pressure gauges in fluid piping adjacent to inlet and outlet connections of the evaporator.
- H. Provide and install drain valves with capped hose ends to each fluid box.
- I. Install vent cocks to each fluid box.

### 3.2 Work By Temperature Control Contractor

- A. Furnish interlock wiring per manufacturer's recommendations and install loose control components furnished by chiller manufacturer.

### 3.3 Work By Electrical Contractor

- A. Furnish power wiring to chiller control panel and obtain required code approval.
- B. Furnish and install approved disconnect switch and short circuit protection and short circuit protection.

**Malaysia**

Lot 5755-6, Kidamai Industrial Park,  
Bukit Angkat,  
43000 Kajang,  
Selangor Darul Ehsan,  
Malaysia

Tel: 603-8924 9000  
Fax: 603-8739 5020

**China**

No. 1 Dunham-Bush Road,  
Laishan District,  
Yantai,  
Shandong Province,  
China 264003

Tel: 86-535-658 8999  
Fax: 86-535-658 1999

**Europe****United Kingdom**

8 Downley Road,  
Havant, Hampshire,  
England PO9 2JD

Tel: 44-23-9247 7700  
Fax: 44-23-9245 0396

**Middle East & North Africa****United Arab Emirates**

Al Murad Tower, Office 506  
Al-Barsha 1,  
P. O. Box #30922,  
Dubai, UAE

Tel: 971-4-451 9899  
Fax: 971-4-451 9881

**Asia****Singapore**

2, Kallang Pudding Road #07-07,  
Mactech Industrial Building,  
Singapore 349307

Tel: 65-6842 2012  
Fax: 65-6842 2013

**Africa****South Africa**

No. 57 Sovereign Drive  
Route 21 Corporate Park  
Irene, Pretoria  
South Africa

Tel: 27-12-345 4202  
Fax: 27-12-345 4203

**DUNHAM-BUSH**

info@dunham-bush.com  
www.dunham-bush.com

Products that perform...By people who care